

FULL COMPLEMENT NEEDLE ROLLERS

FG ..SW

3.6

Full complement needle followers
with outer diameter from 16 to 270 mm

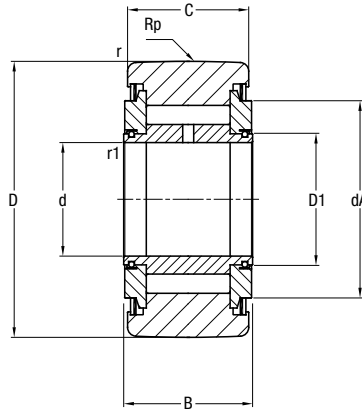

∅ outer D mm	Designation ¹⁾	d ²⁾ mm	B mm	C mm	D ₁ mm	d _A ³⁾ mm	r mm	r ₁ mm	R _p ⁴⁾ mm
	FG ..SW								
16	5 16	5	12	11	7,1	10,4	0,3	0,3	500
19	6 19	6	12	11	8,1	12,6	0,3	0,3	500
24	8 24	8	13	12	10,8	15,5	0,3	0,3	600
	8 24 15	8	15	14	10,8	15,5	0,3	0,3	600
30	10 30	10	15	14	13,8	22	0,6	0,3	700
32	12 32	12	15	14	14,6	22	0,6	0,3	700
35	15 35	15	19	18	18,7	26	0,6	0,3	800
40	17 40	17	21	20	21,1	31	0,6	0,3	1000
47	20 47	20	25	24	25,7	35	1	0,3	1200
52	25 52	25	25	24	29,5	35	1	0,3	1200
62	30 62	30	29	28	34,8	45	1	0,3	1500
72	35 72	35	29	28	39,9	45	1	0,6	1500
80	40 80	40	32	30	46,6	61,1	1	0,6	1700
85	45 85 ⁵⁾	45	32	30	51	61,1	1	0,6	1700
90	50 90	50	32	30	59	71	1	0,6	1700
100	55 100	55	36	34	61,3	71	1,5	0,6	2000
110	60 110	60	36	34	67	77	1,5	0,6	2000
120	65 120	65	42	40	74	83	1,5	0,6	2500
125	70 125 ⁵⁾	70	42	40	80	91	1,5	0,6	2500
130	75 130 ⁵⁾	75	42	40	82	94	1,5	0,6	2500
140	80 140	80	48	46	87	100	2	1	2800
150	85 150 ⁵⁾	85	48	46	94	105	2	1	2800
160	90 160 ⁵⁾	90	54	52	100,9	115	2	1	3000
170	95 170	95	54	52	107	120	2	1	3000
180	100 180	100	65	63	112	128	2	1,5	4000
200	110 200 ⁵⁾	110	65	63	122,5	138	2	1,5	4000
215	120 215 ⁵⁾	120	65	63	130,1	145	2	1,5	4000
230	130 230 ⁵⁾	130	78	75	150	168	3	1,5	4500
250	140 250 ⁵⁾	140	78	75	162	183	3	1,5	4500
270	150 270 ⁵⁾	150	78	75	168	188	3	1,5	4500

FULL COMPLEMENT NEEDLE ROLLERS

FG ..SW

3.6



C _w	Load coefficients (N)		Speed limit greasing (min ⁻¹)	Weight Kg	Designation FG ..SW
	Din F _r	Stat. F _{or}			
4900	4900	5300	5000	0,016	5 16
5600	5800	6600	4100	0,019	6 19
7600	10000	10000	3400	0,037	8 24
9200	13000	13000	3400	0,044	8 24 15
13000	12000	15000	2600	0,066	10 30
12000	17000	18000	2500	0,077	12 32
17000	15000	24000	2000	0,103	15 35
22000	21000	34000	1800	0,155	17 40
27000	22000	35000	1500	0,295	20 47
29000	33000	54000	1400	0,31	25 52
38000	43000	69000	1100	0,49	30 62
43000	56000	87000	1000	0,67	35 72
52000	66000	110000	870	0,89	40 80
54000	68000	110000	810	0,97	45 85 ⁵⁾
49000	57000	93000	710	1,04	50 90
66000	100000	150000	670	1,35	55 100
71000	120000	170000	620	1,65	60 110
81000	140000	210000	560	2,35	65 120
84000	140000	220000	530	2,5	70 125 ⁵⁾
84000	140000	220000	510	2,65	75 130 ⁵⁾
110000	190000	280000	480	3,4	80 140
110000	200000	300000	440	4	85 150 ⁵⁾
130000	320000	340000	420	5,3	90 160 ⁵⁾
130000	250000	390000	390	6	95 170
180000	280000	460000	360	8,05	100 180
200000	380000	550000	340	10	110 200 ⁵⁾
220000	460000	620000	320	11,5	120 215 ⁵⁾
250000	340000	560000	280	15,5	130 230 ⁵⁾
280000	410000	670000	260	18,5	140 250 ⁵⁾
300000	540000	860000	250	22	150 270 ⁵⁾

1) Cam follower without stud designation
 FG..SW Cam follower without stud with optimised outer profile ring without seal
 Suffix..EE With plastic seals available up to outer diameter of 90 mm e.g. FG40EESW
 Suffix ..EEM With metal seals e.g. FG40EEMSW
 FGL..SW Cam follower with cylindrical outer ring

2) Recommended diameter for pivot: h5

3) Minimum recommended abutment support diameter in the event of excessive axial load or if there are vibrations

4) Convex radius in the central part to contact pressure calculation

5) Product available on request