

Linear Rail System

SBI High-load Linear Rail System

SBI-SLS/SL/SLL

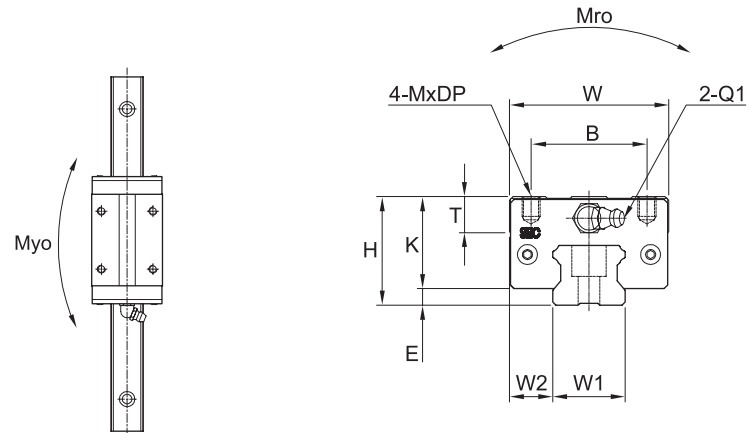

Model	Mounting dimension				Block dimensions												
	H	W	L	E	Mounting tap hole				L1	T±1	K	Grease fitting					
					B	J	M	DP				T1	N1	T2	N2	Q1	*Q2
SBI15 SLS	28	34	56.8	3	26	26	M4	5	38.2	10	25	8.5	5.5	7.8	3.8	M4x0.7	Ø3.5
SBI15 SL	28	34	63.8	3	26	26	M4	5	45.2	10	25	8.5	5.5	7.8	3.8	M4x0.7	Ø3.5
SBI15 SLL	28	34	79.4	3	26	34	M4	5	60.8	10	25	8.5	5.5	7.8	3.8	M4x0.7	Ø3.5
SBI20 SLS	30	44	73.8	4.6	32	36	M5	5	51.8	10	25.4	6	12	5.8	5	M6x0.75	Ø3.5
SBI20 SL	30	44	78.8	4.6	32	36	M5	5	56.8	10	25.4	6	12	5.8	5	M6x0.75	Ø3.5
SBI20 SLL	30	44	96.4	4.6	32	50	M5	5	74.4	10	25.4	6	12	5.8	5	M6x0.75	Ø3.5
SBI25 SLS	40	48	83	5.5	35	35	M6	8	61	16	34.5	10	12	9	5	M6x0.75	Ø3.5
SBI25 SL	40	48	92	5.5	35	35	M6	8	70	16	34.5	10	12	9	5	M6x0.75	Ø3.5
SBI25 SLL	40	48	108	5.5	35	50	M6	8	86	16	34.5	10	12	9	5	M6x0.75	Ø3.5
SBI30 SLS	45	60	96.8	7	40	40	M8	10	68.8	12	38	11.5	12	10.8	5	M6x0.75	Ø5.7
SBI30 SL	45	60	107.6	7	40	40	M8	10	79.6	12	38	11.5	12	10.8	5	M6x0.75	Ø5.7
SBI30 SLL	45	60	131.6	7	40	60	M8	10	103.6	12	38	11.5	12	10.8	5	M6x0.75	Ø5.7
SBI35 SLS	55	70	108.2	8	50	50	M8	10	78.2	15	47	15	12	15	6	M6x0.75	Ø5.7
SBI35 SL	55	70	124.6	7.5	50	50	M8	10	94.6	15	47.5	15	12	15	6	M6x0.75	Ø5.7
SBI35 SLL	55	70	152.6	7.5	50	72	M8	10	122.6	15	47.5	15	12	15	6	M6x0.75	Ø5.7
SBI45 SL	70	86	142	9	60	60	M10	13	108	17	61	20.5	13.5	19.3	6.5	PT1/8	Ø5.7
SBI45 SLL	70	86	174	9	60	80	M10	13	140	17	61	20.5	13.5	19.3	6.5	PT1/8	Ø5.7
SBI55 SL	80	100	172.4	12	75	75	M12	18	131	21	68	22	13	22	8	PT1/8	Ø8.7
SBI55 SLL	80	100	211.8	12	75	95	M12	18	170.4	21	68	22	13	22	8	PT1/8	Ø8.7
SBI65 SL	90	126	219.8	19	76	70	M16	16	170.4	26	71	14	13	14	10	PT1/8	Ø8.7
SBI65 SLL	90	126	272.2	19	76	120	M16	16	222.8	26	71	14	13	14	10	PT1/8	Ø8.7

- ① C (Basic dynamic load rating), Co (Basic static load rating)
- ② *Q2: The hole of side grease nipple is not made to prevent a foreign substance from going into inside. When you order the side grease nipple, we build it by ourselves.

Linear Rail System

SBI High-load Linear Rail System

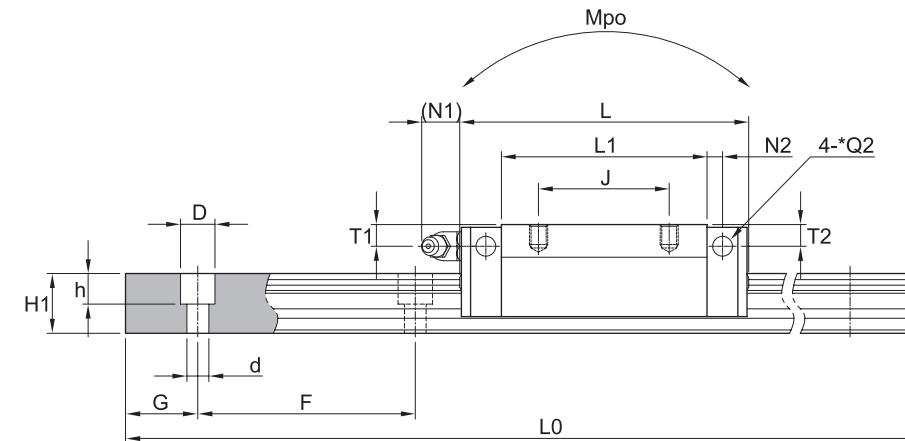

(Unit : mm)

Rail dimension										Basic load rating		Permissible static moment			Mass	
W1	W2	H1	F	Bolt hole			G	Max length of rail	C	Co	Mro	Mpo	Myo	Block [kg]	Rail [kg/m]	
				d	D	h										
15	9.5	13	60	4.5	7.5	5.5	20	3000	12.3	18.3	0.13	0.08	0.08	0.19	1.3	
15	9.5	13	60	4.5	7.5	5.5	20	3000	14.1	24.1	0.16	0.17	0.17	0.23	1.3	
15	9.5	13	60	4.5	7.5	5.5	20	3000	17.1	31.7	0.21	0.29	0.29	0.31	1.3	
20	12	16.5	60	6	9.5	8.5	20	4000	20.2	29.1	0.29	0.18	0.18	0.33	2.2	
20	12	16.5	60	6	9.5	8.5	20	4000	22.2	38.2	0.36	0.33	0.33	0.36	2.2	
20	12	16.5	60	6	9.5	8.5	20	4000	27.9	50	0.47	0.56	0.56	0.47	2.2	
23	12.5	20	60	7	11	9	20	4000	28.9	42.8	0.49	0.32	0.32	0.58	3	
23	12.5	20	60	7	11	9	20	4000	31.5	52.1	0.56	0.56	0.56	0.68	3	
23	12.5	20	60	7	11	9	20	4000	36.7	64.4	0.69	0.84	0.84	0.82	3	
28	16	23	80	9	14	12	20	4000	39.2	57.7	0.80	0.49	0.49	0.92	4.25	
28	16	23	80	9	14	12	20	4000	42.8	65.4	0.85	0.77	0.77	1.06	4.25	
28	16	23	80	9	14	12	20	4000	51.3	84.7	1.10	1.30	1.30	1.36	4.25	
34	18	26	80	9	14	12	20	4000	52.0	73.3	1.24	0.71	0.71	1.48	6.02	
34	18	26	80	9	14	12	20	4000	59.5	89.1	1.42	1.28	1.28	1.82	6.02	
34	18	26	80	9	14	12	20	4000	71.3	115.3	1.83	2.12	2.12	2.32	6.02	
45	20.5	32	105	14	20	17	22.5	4000	79.2	116.3	2.48	1.90	1.90	3.08	9.77	
45	20.5	32	105	14	20	17	22.5	4000	94.8	150.5	3.21	3.14	3.14	4.23	9.77	
53	23.5	38	120	16	23	20	30	4000	127.3	181.8	4.81	2.97	2.97	5.04	13.72	
53	23.5	38	120	16	23	20	30	4000	147.9	224.5	5.95	4.78	4.78	5.82	13.72	
63	31.5	53	150	18	26	22	35	4000	188.3	261.7	8.24	5.57	5.57	9.10	23.17	
63	31.5	53	150	18	26	22	35	4000	232.5	354.1	11.15	9.86	9.86	11.98	23.17	