



CAM FOLLOWERS





SUMMARY



PAGE 04	1.0 THE NADELLA GROUP
PAGE 06	2.0 PRODUCT OVERVIEW
PAGE 16	3.0 PRODUCT DETAILS
PAGE 42	4.0 SPECIAL APPLICATIONS
PAGE 48	5.0 ACCESSORIES
PAGE 52	6.0 TECHNICAL SPECIFICATIONS

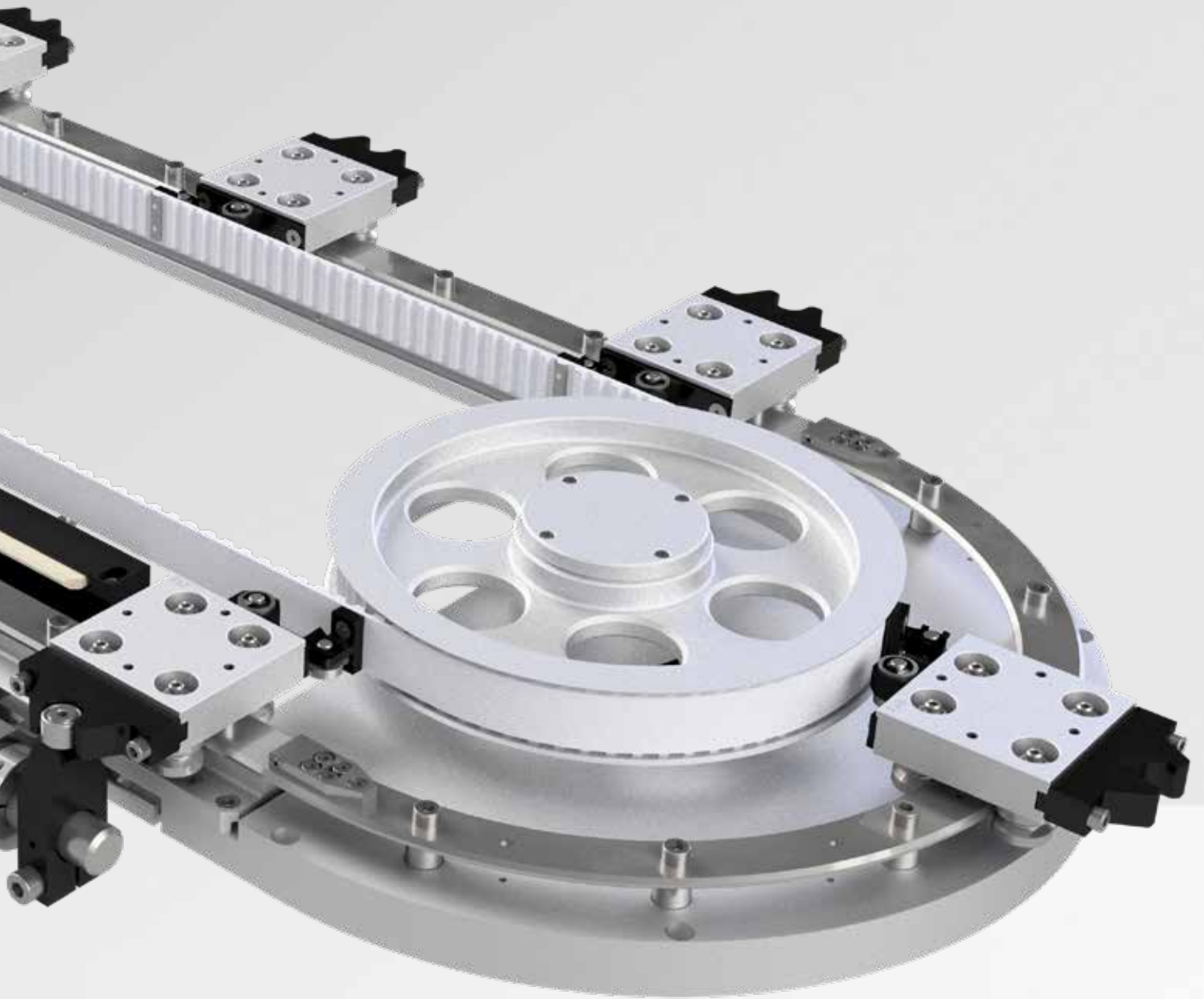

NADELLA GROUP



PAGE 06

1.1 THE GROUP

- Introduction
- Companies, brands and products overview
- Milestones
- Key numbers
- Application sectors

PAGE 07

1.2 THE NETWORK

- Introduction
- Worldwide network
- Branches and contacts
- Distributors coverage

THE SPECIALIST FOR MOTION TECHNOLOGY

Nadella Group is an expert system partner for all areas of **motion technology**, with specialized manufacturer companies and a worldwide sales network.

Wherever innovative ideas, customized solutions, precision and reliability are required, developers and design engineers rely on products and solutions from the **Nadella Group**.

COMPANIES, BRANDS AND PRODUCTS OVERVIEW



Linear Guide Systems



Linear Modules



Complete Systems



Bearings and Cam Followers



Adjusting Nuts & Rings

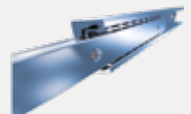

Telescopic Rails



Rod Ends and Spherical Plain Bearings



Clevises and Ball/Axial Joints



Precision Ball Screws



Rolled Ball Screws

MILESTONES

- 1930**
NADELLA foundation in France
- 1958**
Founding of NADELLA GMBH in Germany
- 1963**
Founding of NADELLA S.P.A. in Italy
- 1984**
Start of development and sale of Nadella Linear
- 2012**
New Nadella subsidiaries in China and USA
- 2014**
Acquisition of DURBAL
- 2018**
Acquisition of CHIAVETTE UNIFICATE
- 2020**
New Nadella subsidiaries in France and Spain
Founding of Nadella Motion Technology Changxing Co. Ltd.
Acquisition of SHUTON and IPIRANGA

KEY NUMBERS

1 Group
8 manufacturing plants
14 main locations
Italy, Germany, France, United Kingdom, Spain, United States, China
 leading the way in the international markets
 in over **60** countries
 for **90** years

APPLICATION SECTORS



THE SPECIALIST FOR MOTION TECHNOLOGY

Our customers' satisfaction is the basis for our success and growth. That is why we are at your service around the world and always keep your requirements as a priority.

We have a worldwide network of sales engineers and distributors in Europe, Asia and the USA. This allows us to ensure customer-oriented solutions and best in class delivery and service.

WORLDWIDE NETWORK

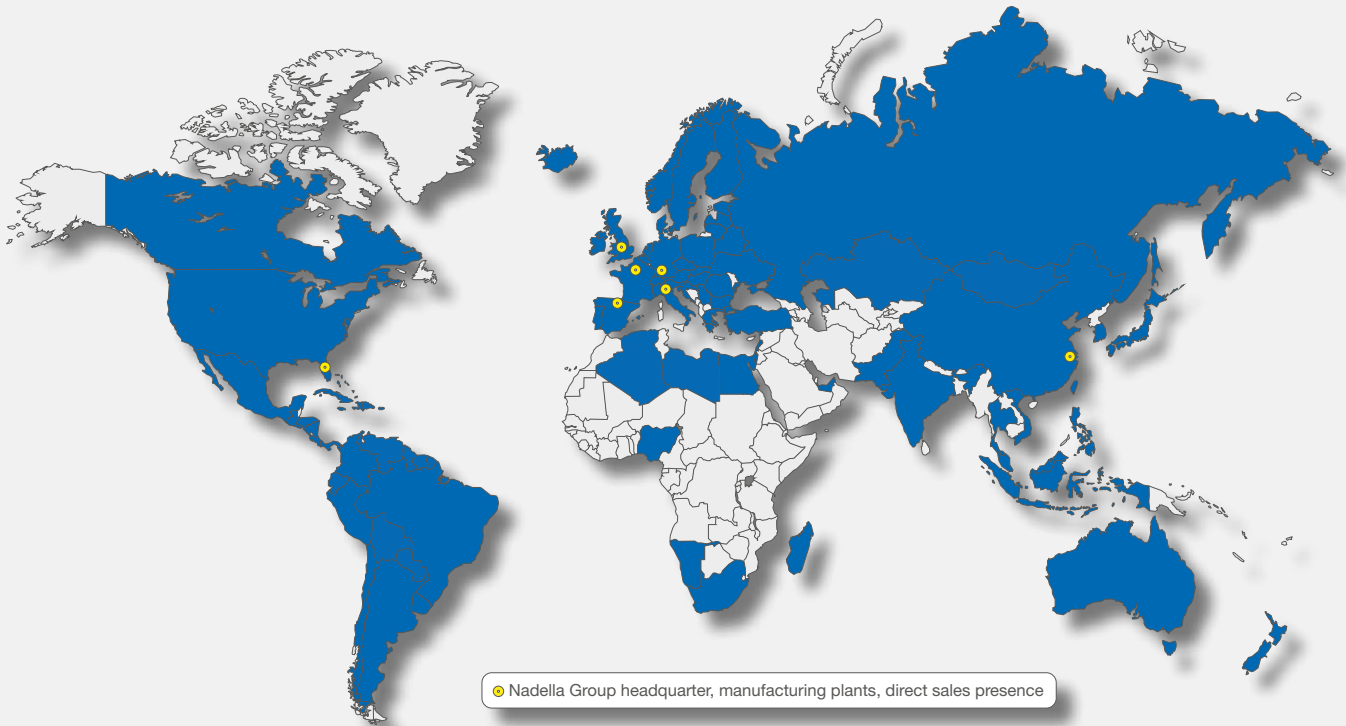

BRANCHES AND CONTACTS

NADELLA S.p.A.
Italy

Via Melette, 16
20128 Milano
Tel.: +39 02 27 093
Fax: +39 02 257 64 79
customer.service@nadella.it
www.nadella.it

NADELLA S.A.
Spain

Poligono Industrial Erratzu
Parcela G3, Pabellón 221 - Apdo.65
E-20130 Umieta - Gipuzkoa
Tel. +34 943 336 370
ventas@nadella.es
www.nadella.com

NADELLA GmbH
Germany

Rudolf-Diesel-Str. 28
71154 Nufringen
Tel.: +49 7032 9540-0
Fax: +49 7032 9540-25
info@nadella.de
www.nadella.de

DURBAL Metallwarenfabrik GmbH - Germany

Verrenberger Weg 2
74613 Öhringen
Tel.: +49 7941 9460-0
Fax: +49 7941 9460-90
info@durbal.de
www.durbal.de

NADELLA Inc.
United States

14115 - 63 Way North
Clearwater - Florida 33760-3621
Tel.: +1 844-537-0330 (toll-free)
Fax: +1 844-537-0331
info@nadella.com
www.nadella.com

CHIAVETTE UNIFICATE S.p.A.
Italy

Via G. Brodolini 6-8-10
40069 Zola Predosa, Bologna
Tel.: +39 051 75 87 67
Fax: +39 051 75 47 80
tescubal@chiavette.it
www.chiavette.com

NADELLA Linear Shanghai Co. Ltd. - China

Room D314, No. 245 Xijunhuan
RoadMinhang, Shanghai 201114
Tel.: +86 21 5068 3835
Fax: +86 21 5038 7725
info@nadellalinear.com
www.nadella.cn.com

SHUTON S.A.
Spain

Poligono Industrial Goian
C/Subimco, 5 - 01170 LEGUATIANO
Tel.: +34 945 465 629
Fax: +34 945 465 610
shuton@shuton.com
www.shuton.com

NADELLA Sarl
France

12 Parvis Colonel Arnaud Beltrame
Hall A 4ème étage
78000 Versailles
Tel.: +33 (0)1 7319 4048
service.client@nadella.fr
www.nadella.fr

HUSILLOS IPIRANGA
Spain

Poligono Industrial Erratzu
Parcela G3, Pabellón 221 - Apdo.65
E-20130 Umieta - Gipuzkoa
Tel. +34 943 336 370
info@ipirangahusillos.com
www.ipirangahusillos.com

DISTRIBUTORS COVERAGE

Austria	China	France	India	Korea	Portugal	Slovakia	Switzerland
Belgium	Czech Republic	Germany	Ireland	Netherlands	Romania	Slovenia	Taiwan
Brazil	Denmark	Great Britain	Israel	Norway	Russia	Spain	Turkey
Canada	Finland	Hungary	Italy	Poland	Singapore	Sweden	United States



PRODUCT OVERVIEW









PAGE 10	2.1 PRODUCT OVERVIEW
PAGE 11	2.2 INTRODUCTION TO CAM FOLLOWERS
PAGE 12	2.3 CAM FOLLOWERS WITH STUD GC ..MINI CAM FOLLOWERS WITH STUD GC ..SW
PAGE 13	2.4 CAM FOLLOWERS WITH STUD KR ..EE FULL COMPLEMENT ROLLERS GCU
PAGE 14	2.5 SMALL CAM ROLLERS FP FULL COMPLEMENT NEEDLE ROLLERS FG..SW
PAGE 15	2.6 FULL COMPLEMENT ROLLERS FGU FULL COMPLEMENT NEEDLE ROLLERS RNA 11000
PAGE 16	2.7 CAM FOLLOWERS WITH PIVOT AND TAPERED BEARINGS PK GUIDE WHEELS FK
PAGE 17	2.8 CAM FOLLOWERS WITH HEAVY STUD PFL DOUBLE CAM FOLLOWERS WITH STUD PFDL

PRODUCT OVERVIEW

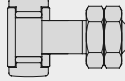
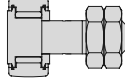
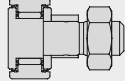
2.1

CAM FOLLOWERS

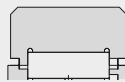
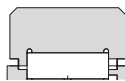
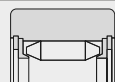
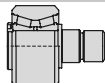
PAGE

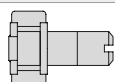
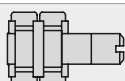
Cam followers with stud GC ..MINI		20
Cam followers with stud GC ..SW		22
Cam followers with stud KR ..EE		24
Full complement rollers GCU		25
Small cam followers without stud FP		28
Full complement needle rollers FG..SW		30
Full complement rollers FGU light series		32
Full complement rollers FGU heavy series		34
Full complement needle rollers RNA 11000		36
Cam followers with pivot and tapered bearings PK		38
Tapered roller bearings FK		39
Cam followers with heavy stud PFL		40
Double cam followers with stud PFDL		42

CAM FOLLOWERS

2.2

NADELLA cam followers are designed to rotate directly on cams, flat surfaces or guidex. In order to meet the unusual conditions of use - significant loads accompanied by substantial and repeated shocks - these types of bearings have the following characteristics:

- Heavy section outer ring, to support the load and minimise the risk of deformations that reduce the bearing's load-supporting capacity.
- Rolling or cup needle roller bearing, with cage or full complement to guarantee maximum load capacity.
- Outer profiled ring to compensate for parallelism errors between the roller and track or cylindrical ring to reduce contact pressure with the sliding surface.
- Lubrication hole with output under the needles to restore the grease through the axle.

The cam followers with stud can be equipped with an eccentric collar to adjust the pre-load during assembly.

The cam followers can be equipped with synthetic or metal seals to retain the grease.

Apart from the products shown in this catalogue, NADELLA produces numerous variants for specific operating conditions.

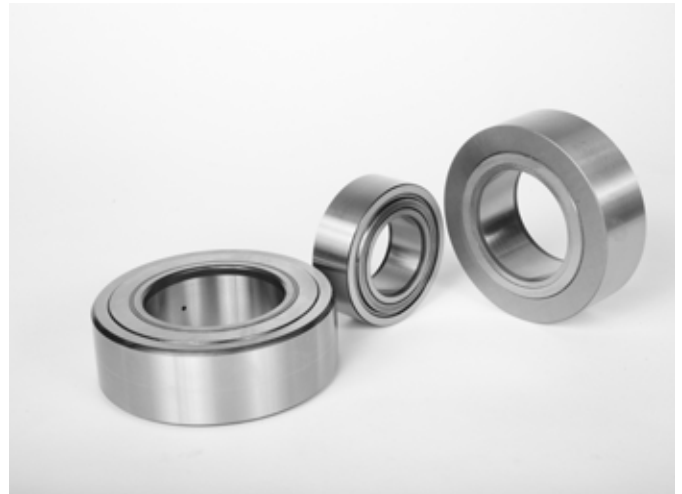

Cam followers with stud GC.. MINI

Full complement needle rollers with outer diameter up to 15mm

- Convex (GC..) or cylindrical (GCL..) outer ring
- Screwdriver slot head side to seal in position while blocking the nut

The mini roller which thanks to the needle roller bearing has the highest load/diameter capacity ratio.

See Page 20



Cam followers with stud GC.. SW

Full complement needle rollers with outer diameter from 16 to 90 mm

New SW version

- Outer ring with optimised profile
- Dimensions compliant with ISO 6278
- More restrictive tolerances compared to ISO 7063
- Built-in hexagonal socket on head side and stud side
- Re-greasing on the head side, stud side and radial on the stud (see tables for restrictions on small sizes)
- Without seals, with plastic (suffix..EE) or metal (suffix...EEM) sliding seals
- With eccentric bearing (GCR..)



This is the classic Nadella cam follower with stud updated with the extension of the adjustment hexagonal socket on each end and for all dimensions. The optimised profile on the outer diameter of the ring was also introduced (see pag. 59 for details)

The full complement of needles guarantees full load capacity and rigidity the careful construction guarantee stricter tolerances compared to the ISO standard, with the tolerances on the outer diameter of the cam follower h6 (instead of h9 in ISO7063).

See Page 22

Cam followers with stud KR.. EE

Cam followers with roller cage and outer diameter from 16 to 90 mm

- Outer ring with convex profile
- Re-greasing on the head side, stud side and radial on the stud (see tables for restrictions on small sizes)
- With axial drag yoke and plastic seal
- With eccentric bearing (KRE..)

The classic cam follower with cage. The need to re-lubricate the bearing, is reduced thanks to the cage and the axial drag yoke. This kind of bearing is suitable for less demanding applications but with elevated speed.

See Page 24



Full complement rollers GCU

Full complement needle rollers with outer diameter from 35 to 130 mm

- Dimensions compliant with ISO 6278
- More restrictive tolerances compared to ISO 7063
- Built-in hexagonal socket on head side and stud side
- Re-greasing on the head side, stud side and radial on the stud
- Without seals, or with metal seals (suffix...MM)
- With eccentric bearing (GCUR..)

This is the classic Nadella full complement roller updated with the extension of the adjustment hexagonal socket on both ends and for all dimensions.



The assembly dimensions, for equivalent sizes, are the same as GC..SW. The roller solutions instead of the needles reduces the thickness of the outer ring and the number of rollers. The maximum load is reduced but the dynamic capacity of the cam follower without stud is increased.

The larger dimensions, up to 130 mm, are the solution with the highest load capacity of all the cam followers with stud.

See Page 25

Mini cam followers without stud FP

Full complement needle rollers with outer diameter from 10 mm to 15 mm

- Convex (FP..) or cylindrical (FPL..) outer ring

The mini roller which thanks to the needle roller bearing has the highest load/diameter capacity ratio.

See Page 28



Full complement needle rollers FG.. SW

Full complement needle rollers with outer diameter from 16 to 250 mm

New SW version

- Outer ring with optimised profile
- Dimensions compliant with ISO 6278
- More restrictive tolerances compared to ISO 7063
- Without seals, with plastic (suffix..EE) or metal (suffix...EEM) sliding seals

The full complement of needle rollers guarantees full load capacity and rigidity. The unusual aspect of this cam roller without stud is the assembly of the axial yokes that are firmly fastened to the inner ring, as if it were one piece.

See Page 30



Full complement rollers FGU

Full complement rollers with outer diameter from 35 to 300 mm. The heavy series differs from the light series in the thickness of the outer ring, from which a greater outer diameter derives and the ability to sustain more significant loads.

- Dimensions compliant with ISO 6278
- More restrictive tolerances compared to ISO 7063
- Without seals, with metal guards (suffix...MM)

The full complement rollers guarantee full load capacity and rigidity. The assembly dimensions, for equivalent sizes, are the same as GC..SW. The roller solutions instead of the needle followers reduces the thickness of the outer ring and the number of rolling elements. The maximum load is reduced but the dynamic capacity of the cam follower without stud is increased.

See Page 32 (light series) and Page 34 (heavy series)



Full complement needle rollers RNA 11000

Ring with full complement of needle rollers, mechanically fastened and separate inner ring. Outer diameter from 19 to 90 mm

See Page 36

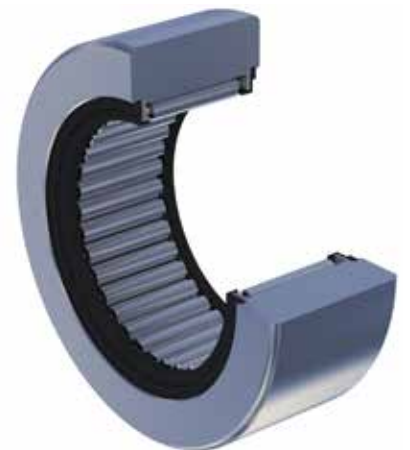

Cam followers with pivot and tapered bearings PK

Cam followers without stud with high load capacity and tapered roller bearings. Outer diameter from 52 to 110 mm

- Version with eccentric stud PKR
- Standard drag seal in NBR
- Possibility of Viton seal for high temperature
- Also available in stainless steel NX

The tapered bearings absorb the axial thrusts due to the misalignments between the cam follower without stud and rolling track without compromising the function of the cam follower without stud. The width of the sleeve allows for the strain to be distributed on a wide contact surface with the rolling track. The amount of grease is sufficient for a life-long greasing of the cam follower without stud. The result is a robust, reliable component.

See Page 38



Guide wheels FK

Cam followers without stud with high load capacity and tapered roller bearings. Outer diameter from 52 to 110 mm

- Standard drag seal in NBR
- Possibility of Viton seal for high temperature
- Also available in stainless steel NX

The tapered bearings absorb the axial thrusts due to the misalignments between the cam follower without stud and rolling track without compromising the function of the cam follower without stud. The width of the sleeve allows for the strain to be distributed on a wide contact surface with the rolling track. The amount of grease is sufficient for a life-long greasing of the cam follower without stud. The result is a robust, reliable component.

See Page 39



Cam followers with heavy stud PFL

Cam followers without stud with high precision and load capacity. Outer diameter of cam follower without stud from 10 to 22 mm

Cam follower with heavy stud and careful construction for use on automatic machinery, positioners and cam movements.

See Page 40



Double cam followers with stud PFDL

For assembly on double contact cam movements. Outer diameter of cam follower without stud from 24 to 32 mm

This is the ideal solution in the applications in which the cam is strained in alternating direction

- Elimination of play between the cam and cam follower without stud in the loading inversion points.
- Elimination of the rotation inversion due to dragging and wear.

See Page 42





PRODUCT DETAILS

3

PAGE 20	3.1 CAM FOLLOWERS WITH STUD GC ..MINI
PAGE 22	3.2 CAM FOLLOWERS WITH STUD GC ..SW
PAGE 24	3.3 CAM FOLLOWERS WITH STUD KR ..EE
PAGE 26	3.4 FULL COMPLEMENT ROLLERS GCU
PAGE 28	3.5 SMALL CAM ROLLERS FP
PAGE 30	3.6 FULL COMPLEMENT ROLLERS FG..SW
PAGE 32	3.7 COMBINED ROLLER FOLLOWERS FGU LIGHT SERIES
PAGE 34	3.8 COMBINED ROLLER FOLLOWERS FGU HEAVY SERIES
PAGE 36	3.9 FULL COMPLEMENT NEEDLE ROLLERS RNA 11000
PAGE 38	3.10 CAM FOLLOWERS WITH PIVOT AND TAPERED BEARINGS PK
PAGE 39	3.11 GUIDE WHEELS FK
PAGE 40	3.12 CAM FOLLOWERS WITH HEAVY STUD PFL
PAGE 42	3.13 DOUBLE CAM FOLLOWERS WITH STUD PFDL

CAM FOLLOWERS WITH STUD TYPE GC ..MINI

Full complement needle rollers with outer diameter to 15mm.



GC, GCL series without seal.

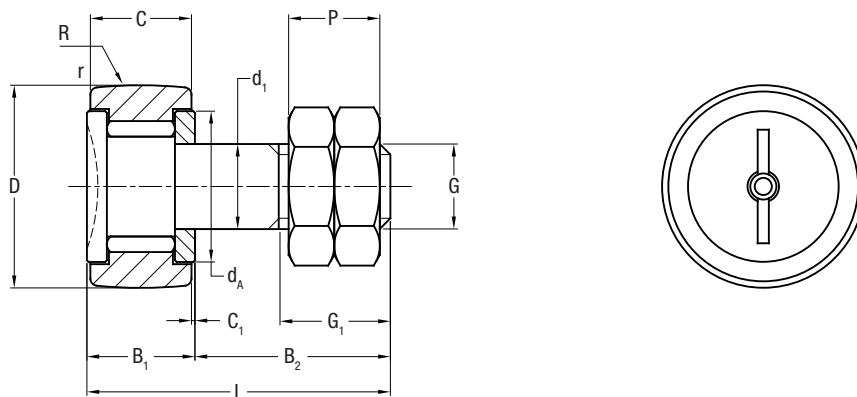

∅ outer D mm	Designation ¹⁾ GC, GCL	d ₁ ²⁾ mm	L mm	B ₁ mm	B ₂ mm	Threading G mm	G ₁ mm	C mm	C ₁ mm	d _A mm	r mm	R ³⁾ mm
10	10	4	19.5	8.5	11	M4x0.7	6	8	0.25	8.4	0.2	130
11	11	4	19.5	8.5	11	M4x0.7	6	8	0.25	8.4	0.2	130
12	12	5	22.5	9.5	13	M5x0.8	7	9	0.25	10.3	0.2	130
13	13	5	22.5	9.5	13	M5x0.8	7	9	0.25	10.3	0.2	130
14	14	6	26	10	16	M6x1	8	9	0.25	11.8	0.3	130
15	15	6	26	10	16	M6x1	8	9	0.25	11.8	0.3	130

1) Cam follower with stud designation

GC.. Concentric cam follower with stud with convex outer ring

GCL.. Concentric cam follower with stud with cylindrical outer ring

2) Hole diameter for assembly d₁ H7

3) Convex radius for GC version..

CAM FOLLOWERS WITH STUD

GC ..MINI

3.1



P mm	Load coefficients (N)			Speed limit with grease (min ⁻¹)	Weight Kg	Clamping torque Nm	∅ outer D mm
	C _w	Din. F _r	Stat. F _{or}				
6	2100	520	960	7500	0.006	0.9	10
6	2400	520	960	7400	0.007	0.9	11
5.4	2900	900	1700	6000	0.011	1.8	12
5.4	3200	900	1700	6000	0.011	1.8	13
6.4	3400	1500	2800	5500	0.016	3	14
6.4	3600	1500	2800	5500	0.018	3	15

The concentric cam followers with stud in the GC Mini series are supplied with two clamping nuts.

CAM FOLLOWERS WITH STUD

TYPE GC .. SW

3.2

Full complement needle rollers with outer diameter from 16 to 90 mm



See page 47 for details on stainless steel versions.

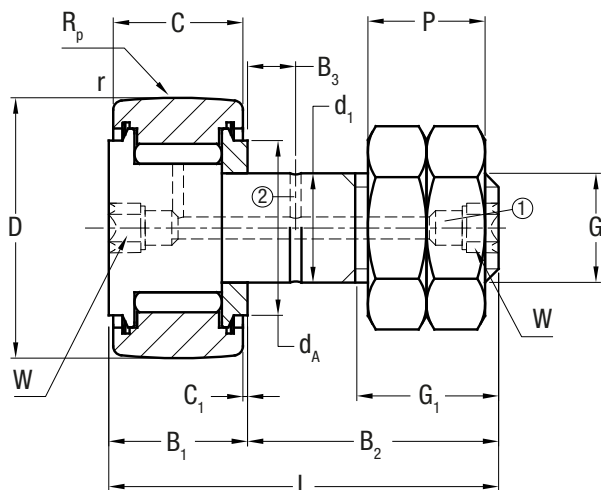

Bore hole ① starting from D=22 mm
Bore hole ② starting from D=30 mm

∅ outer D mm	Designation ¹⁾		d ₁ ²⁾ mm	L mm	B ₁ mm	B ₂ mm	Threading G mm	G ₁ mm	C mm	C ₁ mm	d _A mm	B ₃ mm	r mm	R _p ³⁾ mm
	GC .. SW													
16	16		6	28,2	12,2	16,5	M6x1	8	11	0,6	13,3		0,3	500
19	19		8	32,2	12,2	20,5	M8x1.25	10	11	0,6	15,3		0,3	500
22	22		10	36,2	13,2	23,5	M10x1.25	12	12	0,6	18,2		0,3	600
24	24		10	36,2	13,2	23,5	M10x1.25	12	12	0,6	18,2		0,3	600
26	26		10	36,2	13,2	23,5	M10x1.25	12	12	0,6	20,8		0,3	600
28	28		10	36,2	13,2	23,5	M10x1.25	12	12	0,6	20,8		0,3	600
30	30		12	40,2	15,2	25,5	M12x1.5	13	14	0,6	24,8	6	0,6	700
32	32		12	40,2	15,2	25,5	M12x1.5	13	14	0,6	24,8	6	0,6	700
35	35		16	52,2	19,6	33	M16x1.5	17	18	0,8	28,8	8	0,6	800
40	40		18	58,1	21,6	37	M18x1.5	19	20	0,8	33,8	8	1	1000
47	47		20	66,1	25,6	41	M20x1.5	21	24	0,8	38,7	9	1	1200
52	52		20	66,1	25,6	41	M20x1.5	21	24	0,8	38,7	9	1	1200
62	62		24	80,1	30,6	50	M24x1.5	25	29	0,8	52	11	1	1500
72	72		24	80,1	30,6	50	M24x1.5	25	29	0,8	52	11	1	1500
80	80		30	100	37	63,5	M30x1.5	32	35	1	68	15	1	1700
85	85 ⁹⁾		30	100	37	63,5	M30x1.5	32	35	1	68	15	1	1700
90	90		30	100	37	63,5	M30x1.5	32	35	1	68	15	1	1700

1) Cam follower with stud designation

GC..SW Concentric cam follower with stud optimised profile outer ring

GCL..SW Concentric cam follower with stud cylindrical outer ring (product available on request)

GCR.. Cam follower with stud with eccentric collar

No suffix Without seal

Suffix ..EE With plastic seal, ex. GC40EESW

Suffix ..EEM With metal seal, ex. GC40EEMSW

2) Hole diameter for assembly of concentric cam follower without stud: d₁ H7

3) Convex radius in the central part to contact pressure calculation

CAM FOLLOWERS WITH STUD

TYPE GC .. SW

3.2



See page 47 for details on stainless steel versions.

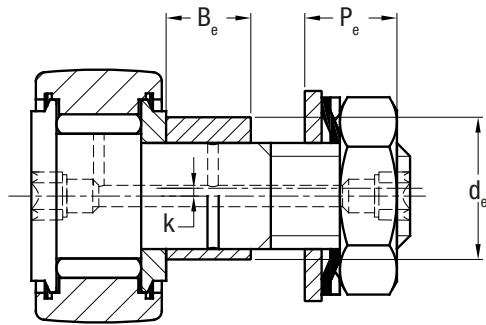

from GCR16SW to GCR52SW

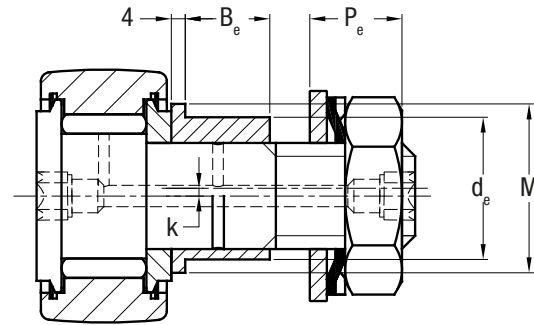

from GCR62SW to GCR90SW

W mm	P ⁷⁾ mm	Eccentric bearing					Load coefficients (N) ⁶⁾			Greasing speed limit with grease (min ⁻¹)	Weight with nuts and washers Kg	Clamping torque Nm	∅ outer D mm
		d _e ^{4) 5)} mm	k ⁵⁾ mm	M ⁵⁾ mm	B _e ⁵⁾ mm	P _e ⁸⁾ mm	C _w	Din. F _r	Stat. F _{or}				
4	6,4	9	0,5		8	5,6	4900	1200	2300	5000	0,024	3	16
4	8	11	0,5		10	6,4	5600	2900	5400	4100	0,039	8	19
4	10	14	1		11	7,9	6900	5300	9400	3400	0,057	20	22
4	10	14	1		11	7,9	7600	5300	9800	3400	0,072	20	24
4	10	14	1		11	7,9	8600	5300	9800	3000	0,08	20	26
4	10	14	1		11	7,9	9200	5300	9800	3000	0,088	20	28
6	12	16	1		11	9,5	13000	7900	15000	2600	0,118	26	30
6	12	16	1		11	9,5	13000	7900	15000	2600	0,126	26	32
10	16	21	1,5		14	12,2	18000	14000	23000	2100	0,22	64	35
12	18	24	1,5		16	13,4	22000	19000	34000	1800	0,321	90	40
14	20	27	2		17,5	14,4	27000	22000	35000	1500	0,5	120	47
14	20	27	2		17,5	14,4	33000	22000	40000	1500	0,568	120	52
12	24	36	3	44	18	17,5	42000	31000	58000	1200	1,035	220	62
12	24	36	3	44	18	17,5	46000	31000	58000	1200	1,278	220	72
14	30	42	3	50	27	20,6	58000	50000	93000	900	2,074	450	80
14	30	42	3	50	27	20,6	61000	50000	93000	900	2,235	450	85
14	30	42	3	50	27	20,6	63000	50000	93000	900	2,435	450	90

4) Hole diameter for assembly of the eccentric cam follower without stud: d_e H7

5) Dimensions of the eccentric bearing.

6) Fr and For load for cam follower without stud, with no eccentric collar.

7) The GC concentric cam followers with stud are supplied with two clamping nuts.

8) GCR eccentric cam followers with stud are supplied with eccentric bearing already fitted, clamping nut, cogged washer and support surface washer.

9) Product available on request

CAM FOLLOWERS WITH STUD

TYPE KR..EE

3.3

Cam followers with stud, with roller cage and outer diameter from 16 to 90 mm

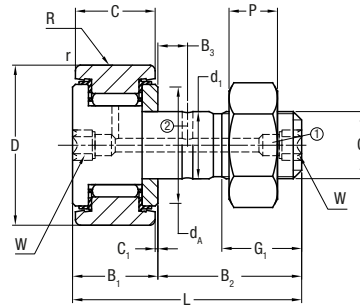

Bore hole ① starting from D=22 mm

Bore hole ② starting from D=30 mm

∅ outer D mm	Designation ¹⁾	d ₁ ²⁾ mm	L mm	B ₁ mm	B ₂ mm	Threading G mm	G ₁ mm	C mm	C ₁ mm	d _A mm	B ₃ mm	r mm	R ⁴⁾ mm
	KR, KR..EE												
16	KR16 ³⁾	6	28	12.2	16	M6x1	8	11	0.6	12.5	-	0.15	500
	KR16EE ³⁾	6	28	12.2	16	M6x1	8	11	0.6	12.5	-	0.15	500
19	KR19 ³⁾	8	32	12.2	20	M8x1.25	10	11	0.6	15	-	0.15	500
	KR19EE ³⁾	8	32	12.2	20	M8x1.25	10	11	0.6	15	-	0.15	500
22	KR22	10	36	13.2	23	M10x1	12	12	0.6	17.5	-	0.3	500
	KR22EE	10	36	13.2	23	M10x1	12	12	0.6	17.5	-	0.3	500
26	KR26	10	36	13.2	23	M10x1	12	12	0.6	17.5	-	0.3	500
	KR26EE	10	36	13.2	23	M10x1	12	12	0.6	17.5	-	0.3	500
30	KR30	12	40	15.2	25	M12x1.5	13	14	0.6	23	6	0.6	500
	KR30EE	12	40	15.2	25	M12x1.5	13	14	0.6	23	6	0.6	500
32	KR32	12	40	15.2	25	M12x1.5	13	14	0.6	23	6	0.6	500
	KR32EE	12	40	15.2	25	M12x1.5	13	14	0.6	23	6	0.6	500
35	KR35	16	52	19.6	32.5	M16x1.5	17	18	0.8	27.6	8	0.6	500
	KR35EE	16	52	19.6	32.5	M16x1.5	17	18	0.8	27.6	8	0.6	500
40	KR40	18	58	21.6	36.5	M18x1.5	19	20	0.8	31.5	8	1	500
	KR40EE	18	58	21.6	36.5	M18x1.5	19	20	0.8	31.5	8	1	500
47	KR47	20	66	25.6	40.5	M20x1.5	21	24	0.8	36.5	9	1	500
	KR47EE	20	66	25.6	40.5	M20x1.5	21	24	0.8	36.5	9	1	500
52	KR52	20	66	25.6	40.5	M20x1.5	21	24	0.8	36.5	9	1	500
	KR52EE	20	66	25.6	40.5	M20x1.5	21	24	0.8	36.5	9	1	500
62	KR62	24	80	30.6	49.5	M24x1.5	25	29	0.8	44	11	1	500
	KR62EE	24	80	30.6	49.5	M24x1.5	25	29	0.8	44	11	1	500
72	KR72	24	80	30.6	49.5	M24x1.5	25	29	0.8	44	11	1.1	500
	KR72EE	24	80	30.6	49.5	M24x1.5	25	29	0.8	44	11	1.1	500
80	KR80	30	100	37	63	M30x1.5	32	35	1	53	15	1.1	500
	KR80EE	30	100	37	63	M30x1.5	32	35	1	53	15	1.1	500
90	KR90	30	100	37	63	M30x1.5	32	35	1	53	15	1.1	500
	KR90EE	30	100	37	63	M30x1.5	32	35	1	53	15	1.1	500

1) Cam follower with stud designation

KR.. Cam follower with stud, with no seals, KR..EE Cam follower with stud with axial drag discs and seals, KRE.. Cam follower with stud with no seals, with eccentric collar, KRE..EE Cam follower with stud with axial drag discs and seals and with eccentric collar.

2) Hole diameter for assembly of concentric cam follower without stud: d₁ H7

3) For 16 and 19 mm diameter the standard cam followers with stud on the head side are supplied with screwdriver slot and grease nipple. The version with built-in hexagonal socket and no grease nipple is identifiable by the SK suffix

CAM FOLLOWERS WITH STUD

TYPE KR..EE

3.3

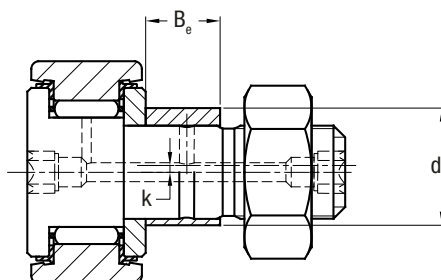

W mm	P mm	Eccentric bearing			Load coefficients (N) ⁶⁾			Speed limit greasing (min ⁻¹)	Weight of nut and washers Kg	Clamping torque Nm	∅ outer D mm
		d _e ^{5) 6)} mm	k ⁶⁾ mm	B _e ⁵⁾ mm	C _w	Din. F _r	Stat. F _{or}				
-	3.2	9	0.5	7	3150	450	3350	14000	0,02	3	16
-	3.2	9	0.5	7	3150	450	3350	14000	0,02	3	16
-	4	11	0.5	9	3500	540	4000	11000	0,032	8	19
-	4	11	0.5	9	3500	540	4000	11000	0,032	8	19
5	5	13	0.5	10	4550	730	5300	8000	0,047	15	22
5	5	13	0.5	10	4550	730	5300	8000	0,047	15	22
5	5	13	0.5	10	5100	840	6400	8000	0,062	15	26
5	5	13	0.5	10	5100	840	6400	8000	0,062	15	26
6	6	15	0.5	11	6800	1220	8600	5500	0,093	22	30
6	6	15	0.5	11	6800	1220	8600	5500	0,093	22	30
6	6	15	0.5	11	7100	1290	9200	5500	0,104	22	32
6	6	15	0.5	11	7100	1290	9200	5500	0,104	22	32
8	8	20	1	14	9700	1830	14300	3600	0,177	58	35
8	8	20	1	14	9700	1830	14300	3600	0,177	58	35
8	9	22	1	16	10900	2090	15800	2900	0,255	87	40
8	9	22	1	16	10900	2090	15800	2900	0,255	87	40
10	10	24	1	18	15400	3400	26000	2400	0,4	120	47
10	10	24	1	18	15400	3400	26000	2400	0,4	120	47
10	10	24	1	18	16600	3800	29000	2400	0,473	120	52
10	10	24	1	18	16600	3800	29000	2400	0,473	120	52
14	12	28	1	22	26000	6800	48000	1900	0,798	220	62
14	12	28	1	22	26000	6800	48000	1900	0,798	220	62
14	12	28	1	22	28000	7200	53000	1900	1,038	220	72
14	12	28	1	22	28000	7200	53000	1900	1,038	220	72
14	15	35	1.5	29	38500	11000	77000	1300	1,665	450	80
14	15	35	1.5	29	38500	11000	77000	1300	1,665	450	80
14	15	35	1.5	29	40500	11700	83000	1300	2,032	450	90
14	15	35	1.5	29	40500	11700	83000	1300	2,032	450	90

4) Convex radius in the standard version. The version with cylindrical outer ring is identifiable by the X suffix. E.g. KR40EEEX

5) Hole diameter for assembly of the eccentric cam follower without stud: d_e H7

6) Dimensions of the eccentric bearing.

7) Fr and For load for cam follower without stud and no eccentric collar

The KR concentric cam followers with stud are supplied with one clamping nut.

The KRE eccentric cam followers with stud are supplied with an eccentric bearing already fitted and one clamping nut.

CAM FOLLOWERS WITH THREADED STUD

TYPE GCU

3.4

Full complement needle followers
with outer diameter from 35 to 130 mm

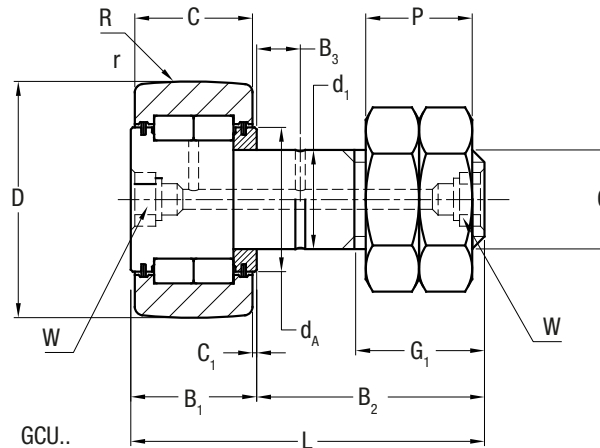

∅ outer D mm	Designation ¹⁾		d ₁ ²⁾ mm	L mm	B ₁ mm	B ₂ mm	Threading G mm	G ₁ mm	C mm	C ₁ mm	d _A mm	B ₃ mm	r mm	R ³⁾ mm
	GCU, GCU..MM													
35	35		16	52.5	19.7	32.8	M16x1.5	17	18	0.85	26	8	0.6	320
40	40		18	58.5	21.7	36.8	M18x1.5	19	20	0.85	28.6	8	1	400
47	47		20	66.5	25.7	40.8	M20x1.5	21	24	0.85	33.6	9	1	500
52	52		20	66.5	25.7	40.8	M20x1.5	21	24	0.85	33.6	9	1	500
62	62		24	80.5	30.7	49.8	M24x1.5	25	29	0.85	38.9	11	1	640
72	72		24	80.5	30.7	49.8	M24x1.5	25	29	0.85	38.9	11	1.1	640
80	80		30	100.5	37.2	63.3	M30x1.5	32	35	1.1	51.8	15	1.1	800
85	85 ⁹⁾		30	100.5	37.2	63.3	M30x1.5	32	35	1.1	51.8	15	1.1	800
90	90		30	100.5	37.2	63.3	M30x1.5	32	35	1.1	51.8	15	1.1	800
100	100		36	117.5	42.2	75.3	M36x3	38	40	1.1	61	20	2	1000
110	110		36	117.5	42.2	75.3	M36x3	38	40	1.1	61	20	2	1000
120	120		42	136.5	48.2	88.3	M42x3	44	46	1.1	71	24	2	1200
130	130		42	136.5	48.2	88.3	M42x3	44	46	1.1	71	24	2	1200

1) Cam follower with stud designation

GCU.. Concentric cam follower with stud and convex outer ring

GCU.. Concentric cam follower with stud and cylindrical outer ring

GCU.. Eccentric cam follower with stud and convex outer ring

GCU.. Eccentric cam follower with stud and cylindrical outer ring

No suffix Without guards

Suffix..MM With metal guards

2) Hole diameter for assembly of concentric cam follower without stud: d₁ H7

3) Convex radius in the standard version GCU.

CAM FOLLOWERS WITH THREADED STUD TYPE GCU

3.4

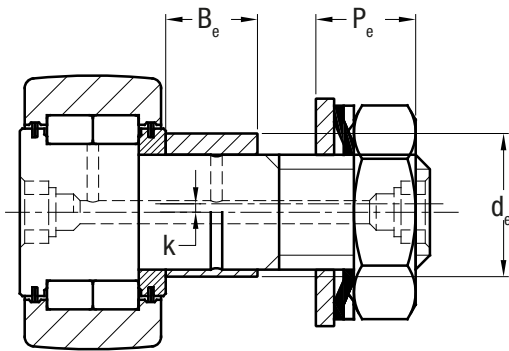

from GCUR35.. to GCUR52..

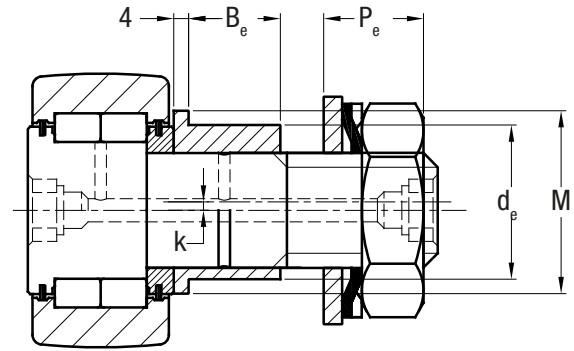

from GCUR62.. to GCUR130..

W mm	P ⁷⁾ mm	Eccentric bearing					Load coefficients (KN) ⁶⁾			Greasing speed limit with grease (min ⁻¹)	Weight of nut and washers Kg	Clamping torque Nm	∅ outer D mm
		d _e ^{4) 5)} mm	k ⁵⁾ mm	M ⁵⁾ mm	B _e ⁵⁾ mm	P _e ⁸⁾ mm	C _w	Din. F _r	Stat. For				
8	16	21	1.5		14	12.2	15.4	7.25	13.1	2200	0.215	64	35
8	18	24	1.5		16	13.4	18.7	12.1	21.8	2200	0.313	90	40
10	20	27	2		17.5	14.4	30.6	21.2	38.2	1600	0.5	120	47
14	20	27	2		17.5	14.4	30.6	21.2	38.2	1600	0.555	120	52
12	24	36	3	44	18	17.5	44.1	30.9	55.6	1400	1.035	220	62
12	24	36	3	44	18	17.5	50.8	52.7	84.1	1400	1.278	220	72
14	30	42	3	50	27	20.6	66.8	43.8	78.8	1000	2.07	450	80
14	30	42	3	50	27	20.6	75.8	68.1	122	1000	2.23	450	85
14	30	42	3	50	27	20.6	75.8	68.1	122	1000	2.47	450	90
17	36	48	3	56	32	24.6	82.1	76.6	135	840	3.38	740	100
17	36	48	3	56	32	24.6	89.7	107	161	840	3.86	740	110
19	42	54	3	62	39	26.8	124	107	193	740	5.1	1200	120
19	42	54	3	62	39	26.8	133	142	228	740	5.59	1200	130

4) Hole diameter for assembly of the eccentric cam follower without stud: d_e H7

5) Dimensions of the pivot with eccentric collar

6) F_r and F_{or} load for cam follower without stud and no eccentric collar

7) The GCU concentric cam followers with stud are supplied with double clamping nut.

8) The GCUR eccentric cam followers with stud are supplied with eccentric bearing already fitted, clamping nut, cogged washer and support surface washer

9) Product available on request

SMALL CAM ROLLERS WITHOUT STUD

FP

3.5

Full complement needle followers
with outer diameter from 10 to 15mm

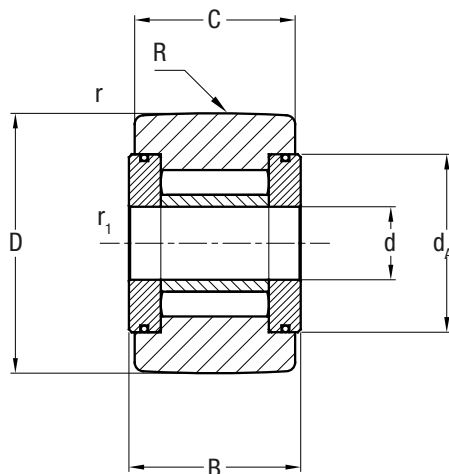

∅ outer D mm	Designation ¹⁾	d ²⁾ mm	B mm	C mm	d _A mm	r mm	r ₁ mm	R ³⁾ mm
	FP, FPL							
10	3 10	3	8.7	8	8.5	0.2	0.15	130
11	3 11 ⁴⁾	3	8.7	8	8.5	0.2	0.15	130
12	4 12	4	9.7	9	9.9	0.2	0.15	130
13	4 13 ⁴⁾	4	9.7	9	9.9	0.2	0.15	130
14	4 14 ⁴⁾	4	10.2	9	11.8	0.3	0.15	130
15	4 15	4	10.2	9	11.8	0.3	0.15	130

1) Designation

FP outer convex ring

FPL outer cylindrical ring

2) Diameter of the pivot to insert in the recommended hole: h5

3) Version FP convex radius

4) Product available on request

SMALL CAM ROLLERS WITHOUT STUD FP

3.5



C _w	Load coefficients (N)		Grease speed limit (min ⁻¹)	Weight Kg
	Din F _r	Stat. F _{or}		
2200	2200	2200	8200	0.004
2300	2300	2300	8200	0.005
3100	3500	3500	6800	0.006
3200	3800	3800	6800	0.008
3300	3900	3900	6800	0.010
3300	3900	3900	6800	0.011

FULL COMPLEMENT NEEDLE ROLLERS

FG ..SW

3.6

Full complement needle followers
with outer diameter from 16 to 270 mm

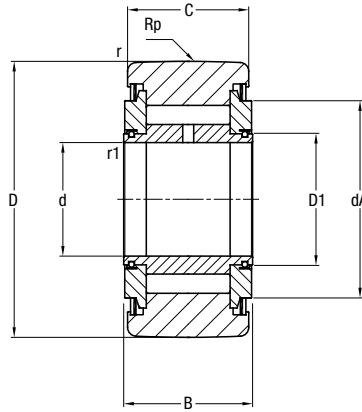

∅ outer D mm	Designation ¹⁾	d ²⁾ mm	B mm	C mm	D ₁ mm	d _A ³⁾ mm	r mm	r ₁ mm	R _p ⁴⁾ mm
	FG ..SW								
16	5 16	5	12	11	7,1	10,4	0,3	0,3	500
19	6 19	6	12	11	8,1	12,6	0,3	0,3	500
24	8 24	8	13	12	10,8	15,5	0,3	0,3	600
	8 24 15	8	15	14	10,8	15,5	0,3	0,3	600
30	10 30	10	15	14	13,8	22	0,6	0,3	700
32	12 32	12	15	14	14,6	22	0,6	0,3	700
35	15 35	15	19	18	18,7	26	0,6	0,3	800
40	17 40	17	21	20	21,1	31	0,6	0,3	1000
47	20 47	20	25	24	25,7	35	1	0,3	1200
52	25 52	25	25	24	29,5	35	1	0,3	1200
62	30 62	30	29	28	34,8	45	1	0,3	1500
72	35 72	35	29	28	39,9	45	1	0,6	1500
80	40 80	40	32	30	46,6	61,1	1	0,6	1700
85	45 85 ⁵⁾	45	32	30	51	61,1	1	0,6	1700
90	50 90	50	32	30	59	71	1	0,6	1700
100	55 100	55	36	34	61,3	71	1,5	0,6	2000
110	60 110	60	36	34	67	77	1,5	0,6	2000
120	65 120	65	42	40	74	83	1,5	0,6	2500
125	70 125 ⁵⁾	70	42	40	80	91	1,5	0,6	2500
130	75 130 ⁵⁾	75	42	40	82	94	1,5	0,6	2500
140	80 140	80	48	46	87	100	2	1	2800
150	85 150 ⁵⁾	85	48	46	94	105	2	1	2800
160	90 160 ⁵⁾	90	54	52	100,9	115	2	1	3000
170	95 170	95	54	52	107	120	2	1	3000
180	100 180	100	65	63	112	128	2	1,5	4000
200	110 200 ⁵⁾	110	65	63	122,5	138	2	1,5	4000
215	120 215 ⁵⁾	120	65	63	130,1	145	2	1,5	4000
230	130 230 ⁵⁾	130	78	75	150	168	3	1,5	4500
250	140 250 ⁵⁾	140	78	75	162	183	3	1,5	4500
270	150 270 ⁵⁾	150	78	75	168	188	3	1,5	4500

FULL COMPLEMENT NEEDLE ROLLERS

FG ..SW

3.6



C _w	Load coefficients (N)		Speed limit greasing (min ⁻¹)	Weight Kg	Designation FG ..SW
	Din F _r	Stat. F _{or}			
4900	4900	5300	5000	0,016	5 16
5600	5800	6600	4100	0,019	6 19
7600	10000	10000	3400	0,037	8 24
9200	13000	13000	3400	0,044	8 24 15
13000	12000	15000	2600	0,066	10 30
12000	17000	18000	2500	0,077	12 32
17000	15000	24000	2000	0,103	15 35
22000	21000	34000	1800	0,155	17 40
27000	22000	35000	1500	0,295	20 47
29000	33000	54000	1400	0,31	25 52
38000	43000	69000	1100	0,49	30 62
43000	56000	87000	1000	0,67	35 72
52000	66000	110000	870	0,89	40 80
54000	68000	110000	810	0,97	45 85 ⁵⁾
49000	57000	93000	710	1,04	50 90
66000	100000	150000	670	1,35	55 100
71000	120000	170000	620	1,65	60 110
81000	140000	210000	560	2,35	65 120
84000	140000	220000	530	2,5	70 125 ⁵⁾
84000	140000	220000	510	2,65	75 130 ⁵⁾
110000	190000	280000	480	3,4	80 140
110000	200000	300000	440	4	85 150 ⁵⁾
130000	320000	340000	420	5,3	90 160 ⁵⁾
130000	250000	390000	390	6	95 170
180000	280000	460000	360	8,05	100 180
200000	380000	550000	340	10	110 200 ⁵⁾
220000	460000	620000	320	11,5	120 215 ⁵⁾
250000	340000	560000	280	15,5	130 230 ⁵⁾
280000	410000	670000	260	18,5	140 250 ⁵⁾
300000	540000	860000	250	22	150 270 ⁵⁾

1) Cam follower without stud designation
 FG..SW Cam follower without stud with optimised outer profile ring without seal
 Suffix..EE With plastic seals available up to outer diameter of 90 mm e.g. FG40EESW
 Suffix ..EEM With metal seals e.g. FG40EEMSW
 FGL..SW Cam follower with cylindrical outer ring

2) Recommended diameter for pivot: h5

3) Minimum recommended abutment support diameter in the event of excessive axial load or if there are vibrations

4) Convex radius in the central part to contact pressure calculation

5) Product available on request

FULL COMPLEMENT ROLLERS

FGU LIGHT SERIES

3.7

Full complement rollers with outer diameter
from 35 to 270 mm

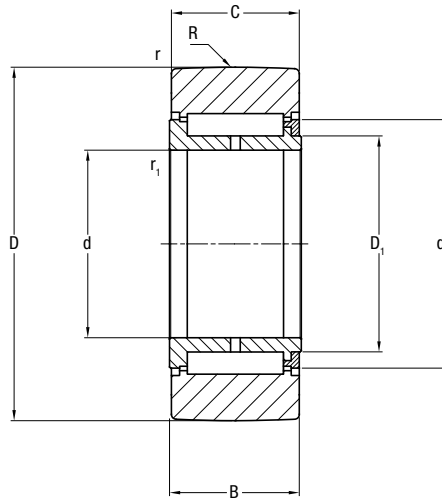
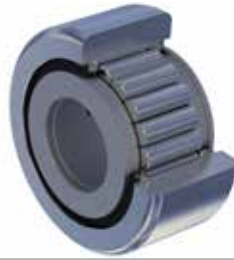

∅ outer D mm	Designation ¹⁾	d ²⁾ mm	B mm	C mm	D ₁ mm	d _A ³⁾ mm	r mm	r ₁ mm	R ⁴⁾ mm
	FGU, FGU ..MM								
35	15 35	15	19	18	19	25.4	1	0.3	320
40	17 40	17	21	20	22	28	1	0.3	400
47	20 47	20	25	24	25.8	33.5	1	0.3	500
52	25 52	25	25	24	30	38.2	1	0.3	500
62	30 62	30	29	28	36.8	45.9	1	0.3	640
72	35 72 ⁵⁾	35	29	28	44	53.6	1	0.6	640
80	40 80 ⁵⁾	40	32	30	49.5	59.3	1	0.6	800
85	45 85 ⁵⁾	45	32	30	54	63.1	1.5	0.6	800
90	50 90 ⁵⁾	50	32	30	59.5	68.8	1.5	0.6	800
100	55 100 ⁵⁾	55	36	34	64	75.8	1.5	0.6	800
110	60 110 ⁵⁾	60	36	34	69.5	81.5	1.5	0.6	800
120	65 120 ⁵⁾	65	42	40	74.5	86.7	2	0.6	900
125	70 125	70	42	40	79.6	91.8	2	0.6	900
130	75 130 ⁵⁾	75	42	40	84	97	2	0.6	900
140	80 140 ⁵⁾	80	48	46	90	102	2	1	1000
150	85 150 ⁵⁾	85	48	46	94	108.5	2	1	1000
160	90 160 ⁵⁾	90	54	52	100	114.7	2	1	1200
170	95 170 ⁵⁾	95	54	52	106.7	121.2	2	1	1200
180	100 180 ⁵⁾	100	65	63	113	127.6	2	1.5	1400
200	110 200 ⁵⁾	110	65	63	122	137	3	1.5	1400
215	120 215 ⁵⁾	120	65	63	132	149.3	3	1.5	1400
230	130 230 ⁵⁾	130	78	75	143	160.6	3	1.5	1600
250	140 250 ⁵⁾	140	78	75	151	168	3	1.5	1600
270	150 270 ⁵⁾	150	78	75	162	179.5	3	1.5	1600

1) Cam follower without stud designation:

FGU.. Cam follower without stud with optimised outer profile ring and no seals

FGU ..MM With metal seals (e.g. FGU 35 72 MM)

FGUL.. Cam follower with cylindrical outer ring

FULL COMPLEMENT ROLLERS

FGU LIGHT SERIES

3.7

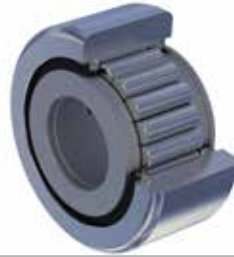

C _w	Load coefficients (N)		Speed limit greasing (min ⁻¹)	Weight Kg	Designation ¹⁾
	Din. F _r	Stat. F _{or}			FGU, FGU ..MM
15000	8100	13000	2200	0.099	15 35
19000	15000	21000	2000	0.142	17 40
28000	25000	30000	1800	0.239	20 47
27000	17000	28000	1500	0.276	25 52
41000	22000	36000	1200	0.461	30 62
52000	46000	67000	1100	0.629	35 72 ⁵⁾
59000	50000	72000	1000	0.831	40 80 ⁵⁾
59000	38000	62000	890	0.895	45 85 ⁵⁾
61000	38000	62000	830	0.963	50 90 ⁵⁾
72000	37000	60000	730	1.35	55 100 ⁵⁾
90000	70000	110000	700	1.672	60 110 ⁵⁾
110000	89000	140000	640	2.364	65 120 ⁵⁾
110000	84000	140000	600	2.48	70 125
110000	79000	130000	670	2.611	75 130 ⁵⁾
140000	120000	190000	540	3.52	80 140 ⁵⁾
140000	130000	200000	500	4.077	85 150 ⁵⁾
180000	160000	260000	480	5.227	90 160 ⁵⁾
190000	180000	290000	460	5.943	95 170 ⁵⁾
240000	240000	390000	430	8.178	100 180 ⁵⁾
260000	290000	470000	390	10.343	110 200 ⁵⁾
280000	320000	510000	370	11.782	120 215 ⁵⁾
350000	340000	550000	340	15.859	130 230 ⁵⁾
380000	400000	650000	310	19.034	140 250 ⁵⁾
430000	590000	810000	310	20.014	150 270 ⁵⁾

2) Recommended diameter for pivot: h5

3) Minimum recommended abutment support diameter in the event of excessive axial load or if there are vibrations

4) Convex radius in the central part to contact pressure calculation

5) Product available on request

FULL COMPLEMENT ROLLERS

FGU HEAVY SERIES

3.8

Full complement rollers with outer diameter from 42 to 320 mm.

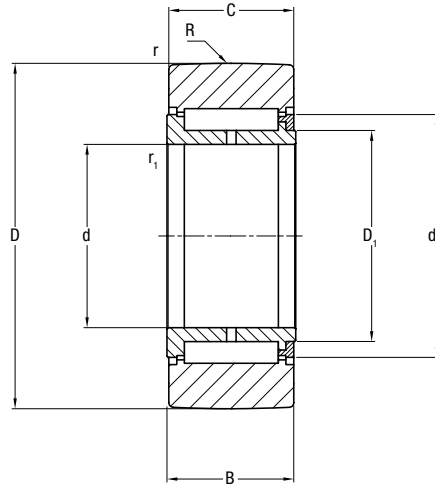
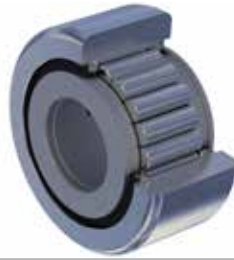

∅ outer D mm	Designation ¹⁾	d ²⁾ mm	B mm	C mm	D ₁ mm	d _A ³⁾ mm	r mm	r ₁ mm	R ⁴⁾ mm
	FGU, FGU ..MM								
42	15 42	15	19	18	19	25.4	1	0.3	320
47	17 47	17	21	20	22	28	1	0.3	400
52	20 52	20	25	24	25.8	33.5	1	0.3	500
62	25 62	25	25	24	30	38.2	1	0.3	500
72	30 72	30	29	28	36.8	45.9	1	0.3	640
80	35 80	35	29	28	44	53.6	1	0.6	640
90	40 90 ⁵⁾	40	32	30	49.5	59.3	1	0.6	800
100	45 100	45	32	30	54	63.1	1.5	0.6	800
110	50 110	50	32	30	59.5	68.8	1.5	0.6	800
120	55 120	55	36	34	64	75.8	1.5	0.6	800
130	60 130	60	36	34	69.5	81.5	1.5	0.6	800
140	65 140	65	42	40	74.5	86.7	2	0.6	900
150	70 150	70	42	40	79.6	91.8	2	0.6	900
160	75 160 ⁵⁾	75	42	40	84	97	2	0.6	900
170	80 170	80	48	46	90	102	2	1	1000
180	85 180 ⁵⁾	85	48	46	94	108.5	2	1	1000
190	90 190 ⁵⁾	90	54	52	100	114.7	2	1	1200
200	95 200	95	54	52	106.7	121.2	2	1	1200
215	100 215	100	65	63	113	127.6	2	1.5	1400
240	110 240 ⁵⁾	110	65	63	122	137	3	1.5	1400
260	120 260 ⁵⁾	120	65	63	132	149.3	3	1.5	1400
280	130 280 ⁵⁾	130	78	75	143	160.6	3	1.5	1600
300	140 300	140	78	75	151	168	3	1.5	1600
320	150 320 ⁵⁾	150	78	75	162	179.5	3	1.5	1600

1) Cam follower without stud designation

FGU.. Cam follower without stud with optimised outer profile ring and no seals

FGU ..MM With metal seals e.g. FGU 35 80 MM

FGUL.. Cam follower without stud with cylindrical outer ring

FULL COMPLEMENT ROLLERS

FGU HEAVY SERIES

3.8

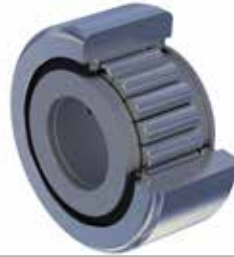

C _w	Load coefficients (N)		Speed limit greasing (min ⁻¹)	Weight Kg	Designation ¹⁾
	Din F _r	Stat. F _{or}			FGU, FGU ..MM
23000	26000	26000	2200	0.16	15 42
25000	30000	30000	2000	0.22	17 47
34000	40000	40000	1800	0.31	20 52
39000	50000	50000	1500	0.45	25 62
58000	70000	76000	1200	0.7	30 72
64000	88000	88000	1100	0.73	35 80
74000	98000	98000	1000	1.13	40 90 ⁵⁾
83000	120000	120000	890	1.4	45 100
90000	130000	130000	830	1.7	50 110
110000	150000	160000	730	2.27	55 120
120000	180000	180000	700	2.68	60 130
140000	220000	220000	640	3.6	65 140
150000	240000	240000	600	4.17	70 150
150000	260000	260000	570	4.75	75 160 ⁵⁾
180000	330000	330000	540	6.16	80 170
190000	350000	350000	500	6.87	85 180 ⁵⁾
240000	400000	400000	480	8.57	90 190 ⁵⁾
250000	420000	420000	460	9.5	95 200
310000	570000	570000	430	13.54	100 215
330000	630000	630000	390	13.95	110 240 ⁵⁾
350000	670000	670000	370	21.19	120 260 ⁵⁾
460000	860000	860000	340	27.63	130 280 ⁵⁾
480000	910000	910000	310	31.73	140 300
500000	930000	930000	310	35.97	150 320 ⁵⁾

2) Recommended diameter for pivot: h5

3) Minimum recommended abutment support diameter in the event of excessive axial load or if there are vibrations

4) Convex radius in the central part to contact pressure calculation

5) Product available on request

FULL COMPLEMENT NEEDLE ROLLERS

RNA 11000

3.9

Ring with full complement needle rollers,
mechanically fastened and separate inner ring.
Outer diameter from 19 to 90 mm

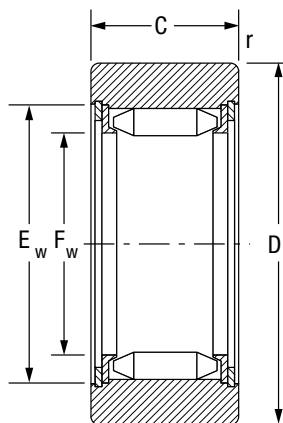

∅ outer D mm	Designation	F _w ²⁾ mm	D ¹⁾ mm	C		E _w mm	r min. mm	Weight g	Load coefficients (N ²⁾
	RNA ..B6			nom. mm	tol. mm				C _w
19	11005 B6	7.3	19	12	0 -0.10	7.3	0.35	19	5100
22	11007 B6	9.7	22	12	0 -0.10	14.7	0,35	25	6000
24	14601 B6	12.1	24	12	0 -0.10	17.1	0.35	27	6200
28	11009 B6	12.1	28	12	-0.20 -0.30	17.1	0.35	42	7400
32	11012 B6	17.6	32	15	-0.20 -0.30	22.6	0.35	57	10800
35	11015 B6	20.8	35	15	-0.20 -0.30	25.8	0.65	62	10800
42	11017 B6	23.9	42	15	-0.20 -0.30	28.9	0.65	98	13400
47	11020 B6	28.7	47	18	-0.20 -0.30	34.7	0.65	133	16800
52	11025 B6	33.5	52	18	-0.20 -0.30	39.5	0.65	152	17200
62	11030 B6	38.2	62	22	-0.20 -0.30	44.2	0.65	275	28500
72	11035 B6	44	72	22	-0.22 -0.34	50	0.65	370	32000
80	11040 B6	49.7	80	22	-0.22 -0.34	55.7	0.85	450	34000
85	11045 B6	55.4	85	22	-0.22 -0.34	62.4	0.85	480	33500
90	11050 B6	62.1	90	24	-0.22 -0.34	68.1	0.85	540	32500

1) Tolerances on the D dimension: h7

2) Recommended tolerance per F_w diameter of the pivot without the use of inner ring: h5

3) Misalignment permitted for convexing the B6 ring: 1.5/1000

FULL COMPLEMENT NEEDLE ROLLERS

RNA 11000

3.9

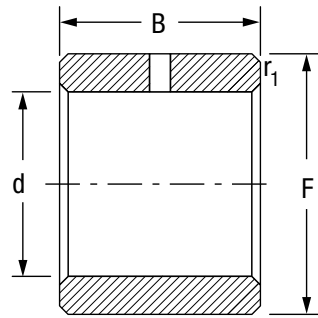

Inner rings

Load coefficients (N) ²⁾		Speed limit with greasing (min ⁻¹)	Inner rings										
Din F _r	Stat. F _{or}		Shaft ∅ mm	Designation BIC series	d mm	F mm	B		r ₁ min mm	Weight g	For cam follower type	∅ outer D mm	
						nom. mm	tol. mm						
4050	4050	8700	-	-	-	-	-	-	-	-	-	-	19
5100	5200	7000	-	-	-	-	-	-	-	-	-	-	22
4700	5600	5800	-	-	-	-	-	-	-	-	-	-	24
7100	7100	5800	-	-	-	-	-	-	-	-	-	-	28
9100	12700	4200	12	BIC 1012	12	17.6	15	0 -0.10	0.35	16	11012	32	
9100	13400	3650	15	BIC 1015	15	20.8	15	0 -0.10	0.65	18	11015	35	
13900	18500	3200	17	BIC 1017	17	23.9	15	0 -0.10	0.65	26	11017	42	
15400	23000	2700	20	BIC 1020	20	28.7	18	0 -0.10	0.65	46	11020	47	
16500	24700	2330	25	BIC 1025	25	33.5	18	0 -0.10	0.65	54	11025	52	
31500	49500	2050	30	BIC 2030	30	38.2	22	0 -0.10	0.65	74	11030	62	
41000	61000	1800	35	BIC 2035	35	44	22	0 -0.12	0.65	93	11035	72	
47000	68000	1620	40	BIC 2040	40	49.7	22	0 -0.12	0.85	115	11040	80	
47500	69000	1450	45	BIC 2045	45	55.4	22	0 -0.12	0.85	139	11045	85	
51000	68000	1300	50	BIC 11050	50	62.1	24	0 -0.12	0.85	196	11050	90	

CAM FOLLOWERS WITHOUT STUD WITH PIVOT AND TAPERED BEARINGS PK

High load capacity cam followers with tapered roller bearings. Outer diameter from 52 to 110 mm

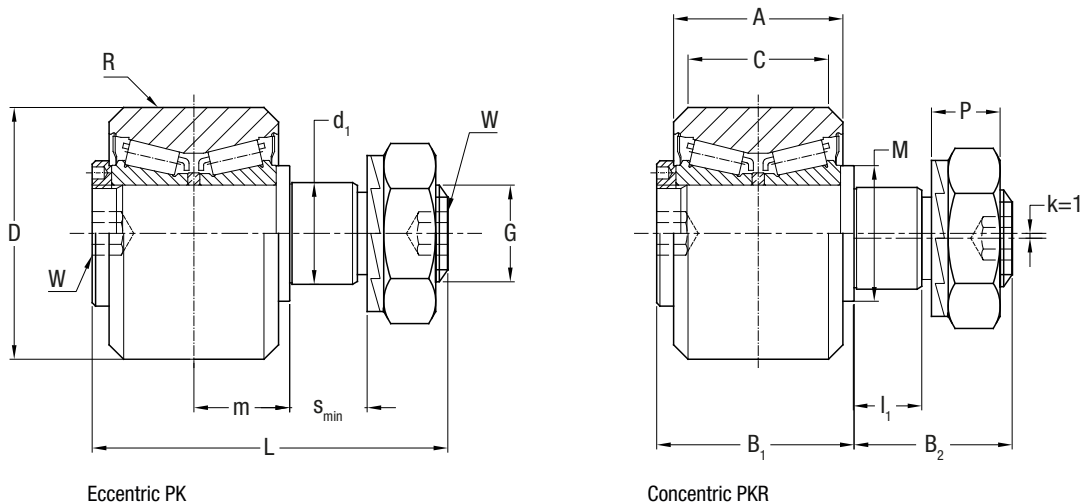

Type concentric	Type eccentric	Dimensions (mm)														Load coefficient (N)				Clamping Nm	Weight Kg	
		D	d ₁ ¹⁾	L	A	B ₁	B ₂	m	C	R	G	I ₁	S _{min}	M	W	P	Cw ²⁾	Cw ³⁾	Din. F _r			Stat. F _{or}
PK 52C	PKR 52C	52	21	73	35	41	32	19.8	29	800	M 20 x 1,5	14	15	28	8	13.4	36000	42000	11900	22000	80	6
PK 62C	PKR 62C	62	27	83	37	44	39	20.8	29	800	M 24 x 1,5	18	19	35	10	15.4	39000	48000	22100	40000	160	9
PK 72C	PKR 72C	72	36	100	45	55	45	27	33	1.2	M 30 x 1,5	18	19	44	12	21.6	54000	69000	31300	58000	300	16
PK 90C	PKR 90C	90	38	115	53	62	53	30	45	1.2	M 36 x 1,5	23	24	50	14	24.6	98000	134000	43800	80000	450	28
PK 110C	PKR 110C	110	42	135	60	70	65	34	48	1.2	M 36 x 1,5	32	33	56	14	24.6	131000	190000	55600	100000	450	49

- 1) Recommended tolerance of the clamping hole in the support: H7
- 2) Coefficient of the calculation for the duration with base 1 million revs
- 3) Coefficient of the calculation for the duration with base 100 km
- 4) AISI 440 stainless steel version available (suffix NX). Inner rolling elements in steel for standard bearing (not stainless)
- 5) Version with Viton seals available (suffix V). Up to and inclusive of diameter size 90

The concentric and eccentric cam followers with stud are supplied complete with self-locking washer and hexagonal nut (DIN 439b)

GUIDE WHEELS

FK

High load capacity cam followers without stud with tapered roller bearings.
Outer diameter from 52 to 110 mmc

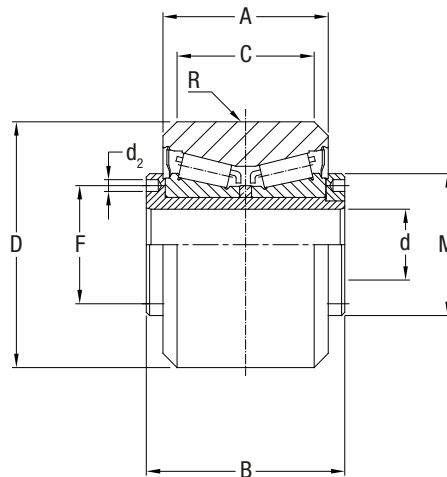

Type	Dimensions (mm)									Load coefficient (N)		Load limit		Weight Kg
	D	d ¹⁾	B	A	C	M	F	d ₂	R	Cw ²⁾	Cw ³⁾	Din. Fr	Stat For	
FK 52C	52	15	42	35	29	25	2.5	30	800	36000	42000	11900	22000	0.5
FK 62C	62	20	45	37	29	29	3	35	800	39000	48000	22100	40000	0.6
FK 72C	72	25	56	45	33	37	4	44	1200	54000	69000	31300	58000	1.2
FK 90C	90	28	64	53	45	42	4	49	1200	98000	134000	43800	80000	2.3
FK 110C	110	35	72	60	48	52	4	59	1200	131000	190000	55600	100000	3.9

1) Recommended tolerance of the clamping pivot: h7 (free coupling)

2) Coefficient of the calculation for the duration with base 1 million revs

3) Coefficient of the calculation for the duration with base 100 km

4) AISI 440 stainless steel version available (suffix NX). Inner rolling elements in steel for standard bearing (not stainless)

5) Version with Viton seals available (suffix V). Up to and inclusive of diameter size 90

CAM FOLLOWERS WITH HEAVY STUD PFL

Cam followers with high precision and load capacity.
Outer diameter of cam follower without stud from 10 to 22 mm

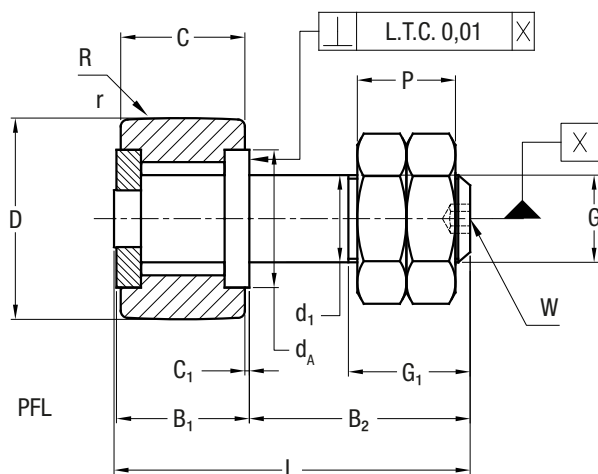

∅ outer D mm	Designation ¹⁾	d ₁ ²⁾ mm	L mm	B ₁ mm	B ₂ mm	Threading G mm	G ₁ mm	C mm	C ₁ mm	d _A mm	r mm	R ³⁾ mm
	PF.. PFL..											
10	10	6	26.5	10	16	M6 x 1	8	9	0.5	8.5	0.5	800
11	11	6	26.5	10	16	M6 x 1	8	9	0.5	8.5	0.5	800
12	12	6	26.5	10	16	M6 x 1	8	9	0.5	9.9	0.5	800
13	13	6	26.5	10	16	M6 x 1	8	9	0.5	9.9	0.05	800
14	14	8	31.5	11	20	M8 x 1.25	10	10	0.5	11.8	0.5	800
15	15	8	31.5	11	20	M8 x 1.25	10	10	0.5	11.8	0.5	800
16	16	8	32.5	12	20	M8 x 1.25	10	11	0.5	13.3	1	800
19	19	10	36.5	13	23	M10 x 1.25	12	12	0.5	15.3	1	800
22	22	10	36.5	13	23	M10 x 1.25	12	12	0.5	18.2	1	800

1) Designation PFL: cam follower with stud and outer cylindrical ring

Designation PF: cam follower with stud and outer convex ring R=800 mm

2) The diameter of the stud is calculated with h6 tolerance. Greasing holes are not foreseen.

3) Convex radius for PF version

CAM FOLLOWERS WITH HEAVY STUD PFL

3.12



W mm	P mm	Load coefficients (N)			Speed limit with grease (min ⁻¹)	Weight Kg	Clamping torque Nm	∅ outer D mm
		C _w	Din. F _r	Stat. F _{or}				
3	6.4	2400	1500	2600	13000	0.011	3	PFL 10
3	6.4	2900	1500	2800	13000	0.013	3	PFL 11
3	6.4	3000	1500	2800	11400	0.014	3	PFL 12
3	6.4	3300	1500	2800	11400	0.015	3	PFL 13
3	8	4200	3200	4200	10100	0.025	8	PFL 14
3	8	4700	3200	4900	10100	0.027	8	PFL 15
3	8	4900	2900	5400	9300	0.031	8	PFL 16
4	10	6300	5300	7900	7600	0.046	20	PFL 19
4	10	6200	5300	8100	6300	0.06	20	PFL 22

CAM FOLLOWERS

DOUBLE PFDL

3.13

For assembling on double contact cam movements.
Outer diameter of cam follower without stud from 24 to 32 mm

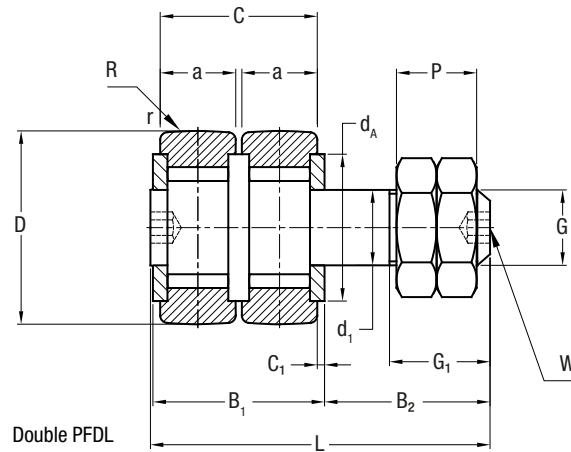

∅ outer D mm	Designation ¹⁾	d ₁ ²⁾ mm	L mm	B ₁ mm	B ₂ mm	Threading G mm	G ₁ mm	C mm	a mm	C ₁ mm	d _A mm	r mm	R ³⁾ mm
	PFDL												
24	PFDL 24.10	10	45	23	21.5	M10 x 1.25	12.5	21	10	1	17.9	1.6	200
28	PFDL 28.10	12	45	22	22.5	M12 x 1.5	13.5	21	10	0.5	20.5	1.6	200
32	PFDL 32.10	12	45	22	22.5	M12 x 1.5	13.5	21	10	0.5	24.5	1.8	250
32	PFDL 32.14	12	60	30	29.5	M12 x 1.5	19	29	14	0.5	24.5	1.8	250

- 1) Designation PFDL, cam follower with outer cylindrical ring
Designation PFD., cam follower with stud and outer convex rings
- 2) The diameter of the stud is calculated with h6 tolerance
- 3) Convex radius for the PFD version

CAM FOLLOWERS

DOUBLE PFDL

3.13



W mm	P mm	Load coefficients (N)			Speed limit with grease (min ⁻¹)	Weight Kg	Clamping torque Nm	∅ outer D mm
		Din C _w ⁴⁾	Din. F _r ⁵⁾	Stat. F _{or} ⁵⁾				
4	10	6900	2000	3700	6300	0.086	20	PFDL 24.10
5	12	5000	2800	4500	5300	0.116	26	PFDL 28.10
5	12	5000	2800	4500	4900	0.144	26	PFDL 32.10
5	12	4300	1900	3000	4800	0.199	26	PFDL 32.14

4) The load coefficient refers to each cam follower without stud of the two cam follower with stud components

5) With load applied to the opposite cam follower on the stud side

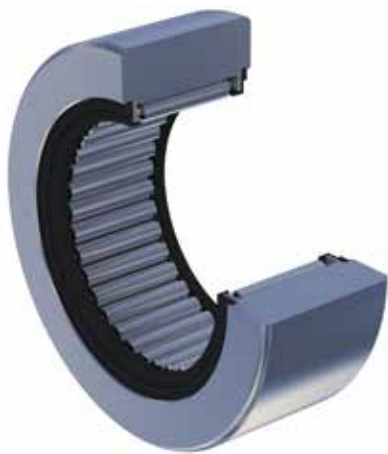

SPECIAL APPLICATIONS



PAGE 46

4.1 SPECIAL APPLICATIONS

- Cam followers without stud with special connections to the greasing system
- Cam followers without stud for cams and indexers
- Anti-corrosion cam followers without stud
- Other products with special shape
- Cam followers without stud for high/low temperature
- Cam followers without stud for vacuum
- Wear-resistant materials
- Mirror finishing

PAGE 48

4.2 OTHER PRODUCTS WITH SPECIAL SHAPE

SPECIAL APPLICATIONS

4.1

As well as the products in the catalogue, Nadella also designs and manufactures special needle and roller cam followers for specific applications. There can be variations on standard products or completely special products. Here are some examples:

CAM FOLLOWER WITHOUT STUD WITH SPECIAL CONNECTIONS TO THE GREASING SYSTEM

PFDL28.10 with threaded hole to connect to the grease dispensing system.

The full complement needle follower generally requires periodical greasing or, for more load and speed strained applications, the oil-filled function. An additional threaded hole in the stud was added to simplify periodical re-greasing connecting the cam roller to a centralised dispensing system.

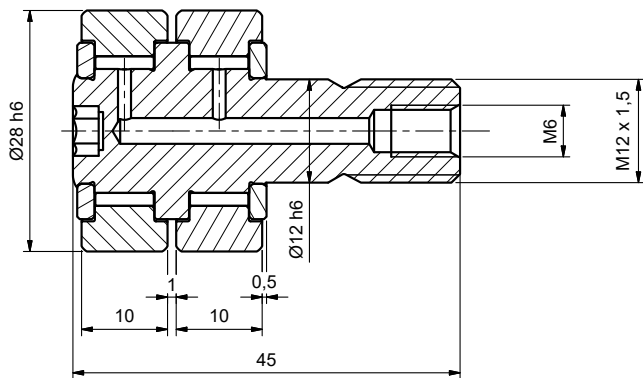

PK52CNX LB cam followers without stud.

The PK series cam followers without stud with tapered bearings are normally considered greased for life. In some environments, for example, where there is a high humidity level, the grease might deteriorate over time and it is, therefore, advisable to take into consideration the possibility of having to top up the grease. The LB option for guide wheels with stud allows you to connect the nipple or plug screw to the threaded hole. For cam followers without stud and with through hole, this allows the grease to be inserted from the pivot (create hole and circular groove on the assembly pivot).

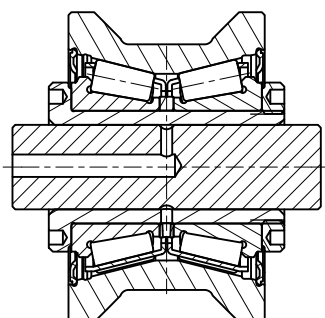
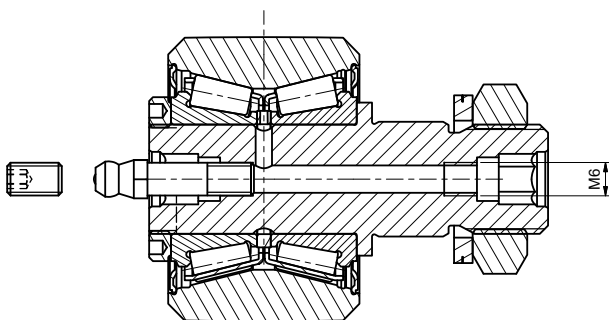

CAM FOLLOWERS FOR CAMS AND INDEXERS

In the case of more complex mechanical applications, cam followers without stud are manufactured with materials, processing cycles, finishings, dimensional tolerances and radial play that are optimised to increase rigidity, load capacity and precision as much as possible.

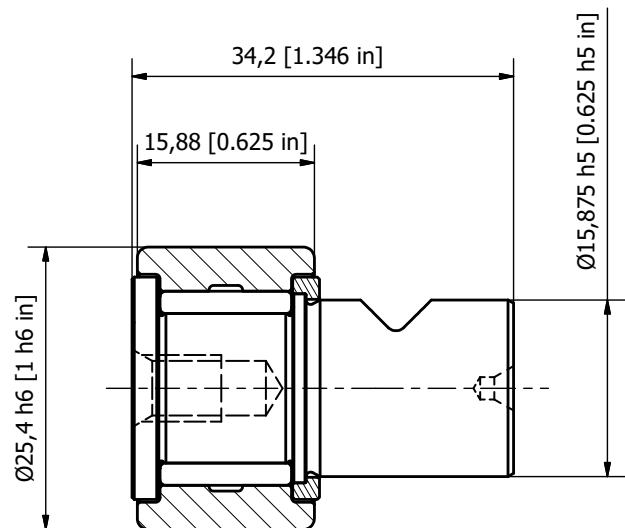
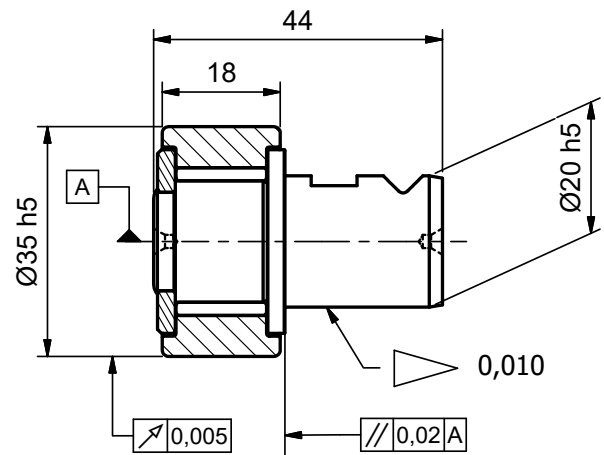

ANTI-CORROSION CAM FOLLOWERS WITHOUT STUD

The cam followers without stud and full complement needle followers can be supplied in anti-corrosion NX version. Nadella offers stainless steel or protected cam followers without stud with surface treatments. The stainless steel used is AISI 400 and achieves a hardness comparable to steel for bearings but has a limited resistance to corrosion. The inner needles can be in stainless steel or more commonly in 100Cr6 steel. In this case the corrosion protection of the needles is entrusted to grease (NSF H1 classified grease for alimentary use and resistant to humidity). Nuts and washers are supplied in A2 stainless steel, the greasing nipple in raw brass or stainless steel.

As an alternative to the stainless steel versions hard nickel or hard chrome treatments can be used.

Different solutions can be configured based on the environment in which it is applied

- **NX-11:** this is the most common version that has outer parts in stainless steel, chromium-plated metal shields, inner needles or rollers in standard bearing steel.
- **NX-12:** outer ring in stainless steel, remaining external components nickel-plated, inner needles or rollers in standard bearing steel.
- **NX-17:** entirely in stainless steel.
- **NX-18:** hard chromium-plated components, needles in standard bearing steel. This is the best option for small production batches.

CAM FOLLOWERS WITHOUT STUD FOR HIGH/LOW TEMPERATURE

These require suitable grease and stabilisation of the material for expected operating temperature.

CAM FOLLOWERS WITHOUT STUD FOR VACUUM

Entirely in stainless steel and slow evaporating grease.

WEAR-RESISTANT MATERIALS

Cam followers without stud with stainless outer ring for wear-resistant tools.

SURFACE FINISHINGS

Mirror polishing and oxidisation to add the colour black.

OTHER PRODUCTS WITH SPECIAL SHAPE

4.2

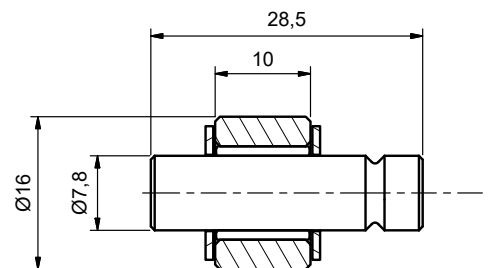
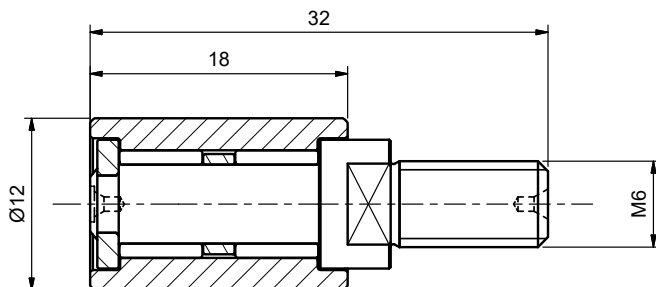
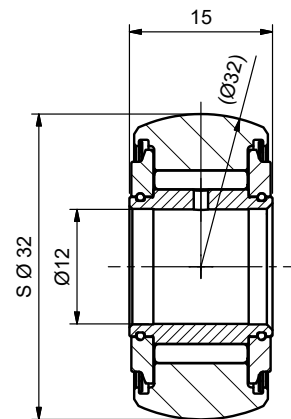
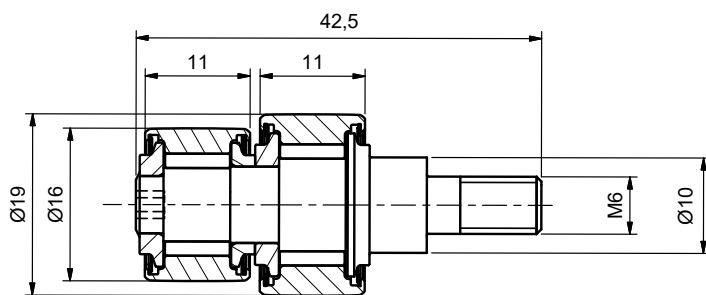
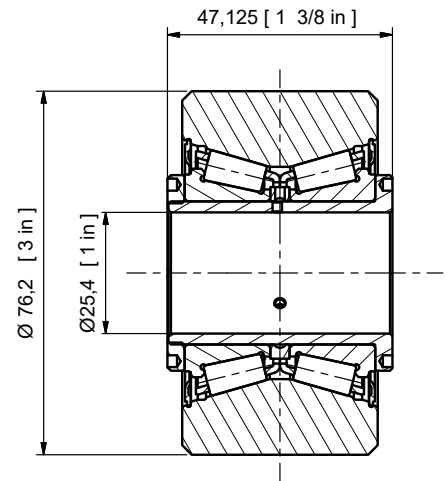
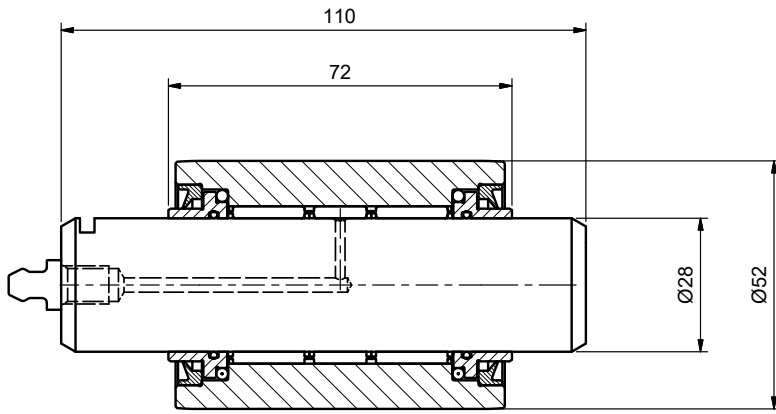

NOTES

A large grid of graph paper for taking notes. The grid consists of 20 columns and 30 rows of small squares.

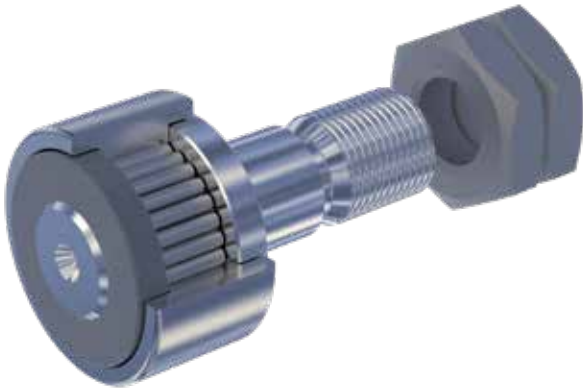

ACCESSORIES



PAGE 52

5.1 ACCESSORIES FOR CAM FOLLOWERS WITH STUD

- Eccentric collars
- Nut and washer
- Nipple and greasing plug
- Greasing injector

ACCESSORIES FOR CAM FOLLOWERS

ECCENTRIC COLLARS

In order to allow for the cam follower with stud bearing position to be adjusted with respect to the hole, eccentric collars slipped onto the stud with interference are used. This way the position of the bearing can be regulated for the value $\pm k$, that is the eccentricity.

The eccentric collar obstructs the greasing hole on the shank of the stud; collars adapted to allow the eccentric cam followers without stud to be greased through the hole in the stud are supplied on request.

The eccentric collars are supplied already fitted to the pivots of the cam follower without stud GCR, GCUR and KRE.

CLAMPING NUT

The cam followers with stud are supplied with nut and washer for assembly. See pages relative to the supply detail.

NIPPLE AND GREASING PLUG

The full complement needle rollers in the GCU and GC..SW series complete with holes for re-greasing and built-in hexagonal socket at both ends. They are supplied with greasing plug and nipple. Insert one or the other in the specific ends depending on which side the re-greasing will be done.

GREASING INJECTOR

The SRG-80 pump with 150 cc capacity can be used to manually re-grease the cam followers.

It should be fitted with a tip suited to the nipple being used.

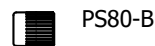
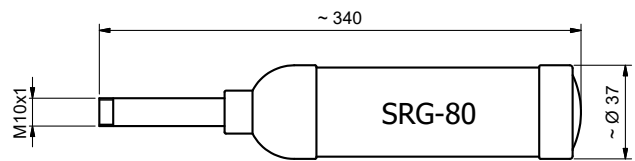

Tip for greasing injector

Cam followers with stud, in the series GCU and GC..SW with GC35 size concave greaser included.	PS80-A
Cam followers with stud, in the series GC..SW with GC16 and GC32 size concave greaser included.	PS80-C
Cam followers without stud with convex head greaser with option ..LB	PS80-B

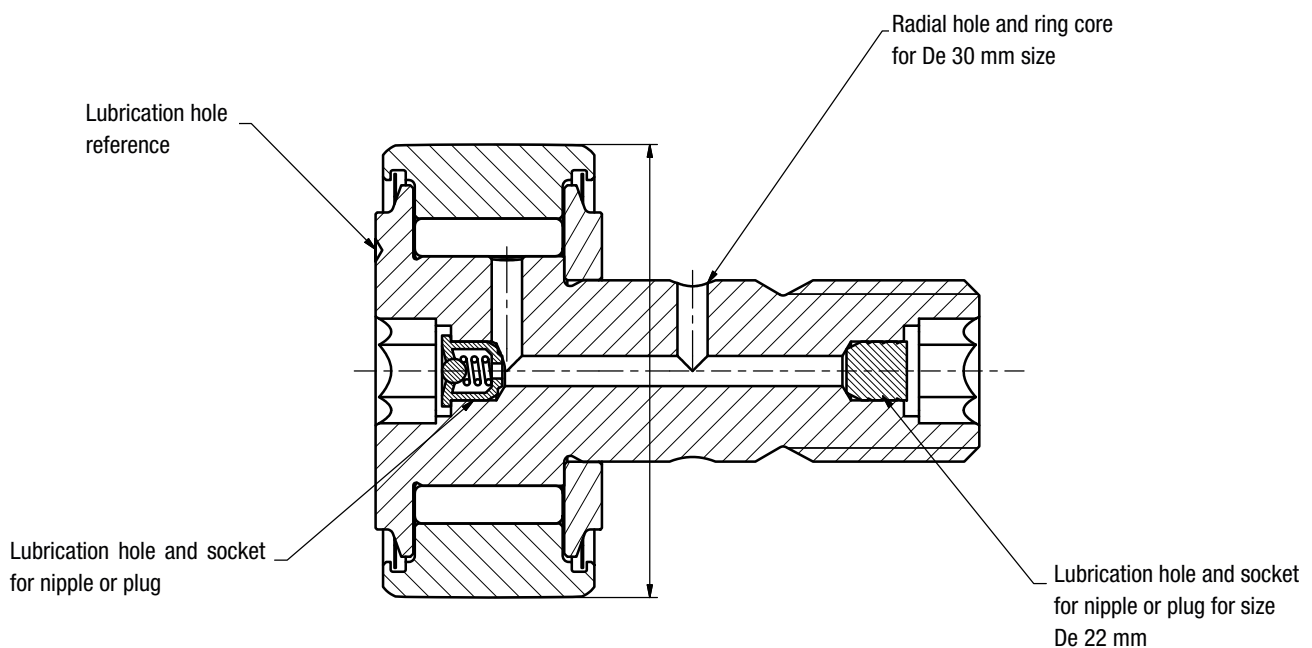

NOTES

A large grid of graph paper for taking notes, consisting of 20 columns and 30 rows of small squares.



TECHNICAL SPECIFICATIONS

6

PAGE 56

6.1 TECHNICAL SPECIFICATIONS

- Reference standards
- Load capacity
- Precision
- Radial play
- Selection of seal type
- Greasing operating temperature
- Optimised profile
- Alignment tolerance permitted between roller and track
- Assembly instructions

TECHNICAL SPECIFICATIONS

REFERENCE STANDARDS

The cam followers in the series GC, KR, FG, GCU and FGU comply with standards:

- ISO 6278 – Contrast rollers – Bulk dimensions
- ISO 7063 – Contrast rollers – Tolerances

LOAD CAPACITY

The cam follower is generally used as a wheel that runs on a guide or cam. The load is applied to the cam follower without stud at the contact point with the race track and, unlike a bearing, the outer ring is not kept in the case and is free to deform. The elastic deformation of the outer ring affects the load distribution between the rolling bearing elements reducing the capacity calculated in compliance with ISO standards for bearings.

The dimensional tables show the load values

- The C_w load coefficient to be used to calculate the duration t . Keep in mind the bearing's load capacity C in compliance with ISO281 based on the rigidity of the outer ring.

$$L_{10} = \left(\frac{C_w}{f_w \cdot P_r} \right)^{10/3}$$

$$L_h = \frac{10^6 \cdot L_{10}}{60 \cdot n}$$

$$L_{km} = L_{10} \cdot \pi \cdot D$$

C_w : dynamic load coefficient of the cam follower without stud for 10^6 revs

f_w : overload factor

P_r : radial load applied in N

L_{10} : duration calculated in millions of revs

L_h : duration in hours

L_{km} : duration in km

n : average speed in revs/minute

Overload factor f_w

1.0 - 1.2	low speed functioning with regular load
1.2 - 1.5	functioning under normal conditions
1.5 - 2.0	functioning with minor shocks and vibrations
2.0 - 4.0	high speed, shocks and vibrations

The maximum load applicable to the cam followers without stud takes into consideration the acceptable load from the bearing (C_0 in accordance with ISO 76 reduced on the basis of the rigidity of the outer ring), the resistance of the outer ring and, for cam followers with stud, the resistance of the stud's resistance. The tables show the applicable limit load.

- Dynamic load limit F_r : this is the load which should not be exceeded when the cam followers without stud are subject to repeated strain.
- Static load limit F_{or} : this is the static resistance limit that the cam follower without stud can bear under exceptional conditions and should never be exceeded.

The safety coefficient f_s can be calculated as

$$f_s = F_r / P_r$$

F_r : Product dynamic limit load

In any event, the applied load P_r needs to be lower than the product's static load F_{or} .

Safety factor f_s minimum recommended

≥ 3	in the event of shocks or vibrations, applications with a need for gentle rolling
≥ 1.5	functioning under normal conditions
≥ 1	almost static applications, without the need for gentle rolling

The load limit F_r and F_{or} for the cam followers with stud in the product tables refers to the concentric version. Assessment will need to be made as to whether the eccentric load can rotate the pivot in its seating, if the GCR or GCUR or KRE eccentric version is used.

Furthermore, the rolling track resistance needs to be taken into consideration. The assessment method adopted is based on the calculation of the Hertz pressure compared to the pressure accepted by the cam material.

The product catalogue data refers to the standard steel version. The stainless steel products or those stabilised by high temperature have a reduced load capacity.

Contact Nadella Technical Assistance for more details.

TECHNICAL SPECIFICATIONS

6.1

PRECISION

Cam followers with stud in the series GC, GCU, FG, FGU, KR refer to the dimensions in standard ISO 6278.

The reference standard for the same products is ISO 7063.

The cam follower manufacturing tolerance given in the tables below are generally more restrictive compared to the reference standard, but in any event, still compliant with the standard.

In particular, the outer diameter of the cam followers without stud is produced in h6 or h7 tolerance even for the versions with profiled or convex outer ring

RADIAL PLAY

The radial play of the standard cam followers without stud normally falls into category C2 established for needle roller bearings in compliance with standard ISO 5753-1.

Cam follower without stud outer diameter tolerance D GC / PF / FG / FL / PFDL / GCU / FGU

Up to diameter 32 inclusive	h6
Beyond diameter 32	h7

Max error on rotation GC / PF / FG / FL / PFDL / GCU / FGU

Diameter d		Kea um
10	18	15
18	30	15
30	50	20
50	80	25
80	120	35
120	150	40
150	180	45
180	240	50

Diameter tolerance on cam follower stud d₁ GC / PF / PFDL / GCU

All dimensions	h6
----------------	----

Cam follower hole tolerance d (Micron) GC / PF / PFDL / GCU

Diameter d		Tolerance um	
from	up to	upper	lower
3	10	0	-8
10	18	0	-8
18	30	0	-10
30	50	0	-12
50	80	0	-15
80	120	0	-20
120	180	0	-25

TECHNICAL SPECIFICATIONS

SELECTION OF SEAL TYPE

The key function of the seals is to protect the bearing from its surrounding environment and treat the grease inside.

- The cam followers with no seal are shown in the applications with oil greasing coming from outside the cam follower without stud (typically high load and speed cams) where it is essential to allow for the entry of the oil in the bearing for greasing and cooling.
- The cam followers with stud in series GC and FG with a diameter of 16 inclusive can fit seals:
 - EEM type, of metal guards, are mechanically resistant and suited to any temperature.
 - EE type seal is manufactured with a Teflon ring in contact with the moving parts. The seal's maximum operating temperature is 220°C.
- Cam followers with stud in the GCU series can be fitted with MM type seals that act as labyrinth metal guards and are suited to any temperature.
- Cam followers without stud in the FGU series can be fitted with MM type seals that act as metal guards and are suited to any temperature.
- The cam followers without stud in the KK..EE series are fitted with plastic seals (not Teflon) integrated with the outer ring's axial containment abutment.
- The cam followers without stud in the PK and FK series fitted with RS type seals in NBR, can be used up to a temperature of 80°C. For temperatures in excess of this, the cam followers without stud up to and including size 90 can be fitted with Viton seals (suffix V). The acceptable temperature of the seal is 200°C.

OPERATIONAL GREASING AND SEAL

The type of cam followers shown in this catalogue, with the exception of the RNA type cam followers without stud are supplied with a grease that permits an operating temperature from -20°C to 120°C. The stainless steel cam followers without stud use a category NSF H1 grease for alimentary purposes.

The RNA 11000 type cam followers without stud are supplied with a protection compatible to a lithium soap based grease. As with bearings, the protection is unsuited for greasing the cam followers without stud. The maximum operating temperature depends on the grease used.

For cam followers and full complement needle followers GC, GCU and derivatives, with metal or plastic seals (EE - Teflon), the operating temperature limit depends on the grease and in the case of standard cam followers without stud, is between -20°C and 120°C.

For full complement needle rollers with cage, the operating temperature is between -20°C and 80°C.

The cam followers without stud with tapered bearings type PK and FK are supplied already greased and in the standard version can operate between -20°C and 80°C (standard seals in NBR) or 120°C (seals in Viton). a suitable grease needs to be used for a higher temperature.

Greased bearings can be provided with suitable grease at high or low temperatures, or with no grease.

For high temperatures starting at 150°C, the products need to undergo stabilising heat treatment which involves a reduction of hardness and load capacity.

OPTIMISED PROFILE

Cam rollers are generally used in contact with the cams or sliding guidex. The contact between the surface of the guide or cam and cam follower without stud is selected on the basis of the application considering the strain caused on the material and the consequences of any misalignments.

Cam followers without stud with **constant radius convex outer ring**. The theoretical point of contact under the effect of elastic deformations caused by the load converts into a surface, the contact pressure is calculated with the classic Hertz formulae and has a parabolic tendency with maximum strain in the centre of the contact area. The maximum value is taken as reference for the resistance assessment requested of the rolling track. As the diameter of the cam follower without stud and the convex radius expands, the contact pressure drops. Any misalignment of the cam follower without stud moves the contact zone without modifying dimension or strain. This is a solution suited to the application with an average load and relatively inexact geometries, typically applications for a linear movement.

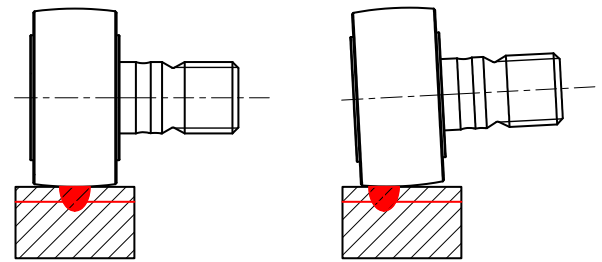

Rollers with convex outer ring with constant radius

Cam followers without stud with **cylindrical outer ring**. The theoretical contact line under the effect of the contact load opens onto a vast surface reducing the average and maximum pressure. As an initial estimate according to the Hertz formulae with equal load, the strain and deformation are considerably lower compared to the contact with the convex cam roller without stud but two important considerations need to be made: 1) at the ends of the contact line, due to the edge, there is a peak in the strain which, in practical terms, reduces the difference compared to the previous case 2) the effect of a misalignment, even a minor one, moves the contact to an extreme prejudicing the contact itself and even the load which weighs on the bearing below. This is a solution suited to applications with a high load and which require the machine to make careful mechanical processings to avoid misalignments.

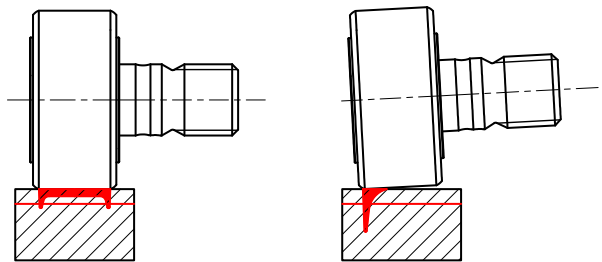

Rollers with cylindrical outer ring

Cam followers without stud with **optimised profile outer ring**. The profile of the cam follower without stud is created with a wide radius in the central part of the sleeve that decreases by moving away from the central line of the cam follower without stud. When the cam follower without stud is properly aligned, the wide radius allows for a vast contact area and excellent distribution of the load; in the event of misalignment between the track and cam follower without stud, the contact moves in a similar fashion to the convex cam followers without reaching the edge of the strip, thus protecting the track and inner bearing against abnormal strain. This is a solution suited both to applications that require a high level of load accuracy and rigidity as well as to applications with misalignments. The cam followers without stud with optimised profile are identified by the SW suffix.

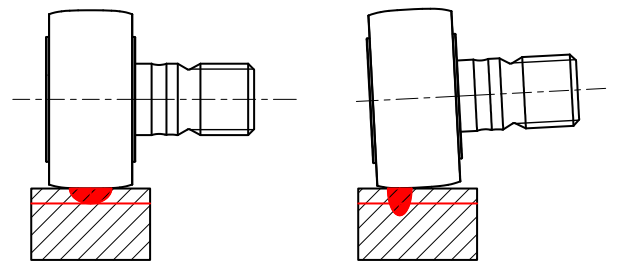

Rollers with convex outer ring with optimised radius.

ALIGNMENT TOLERANCE PERMITTED BETWEEN ROLLER AND TRACK

Cam followers without stud with convex outer ring or optimised profile allow for an inclination compared to the surface of the track, up to a maximum as shown in the table.

Cam follower without stud type	Inclination Δ
RNA 11 000 B6	1.5 per 1000
Cam followers FG, GC, GCU with convex outer ring or optimised profile	7 per 1000

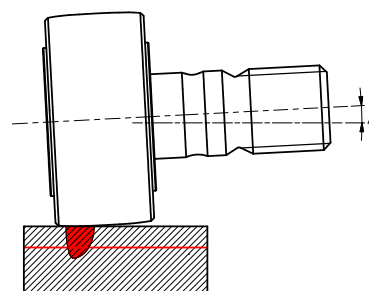

TECHNICAL SPECIFICATIONS

ASSEMBLY INSTRUCTIONS

Direction of the greasing radial hole

In the case of use with heavy loads, shocks or vibrations, it is best to avoid the greasing hole ending up in the area in which the load weighs down on the needles, which is the side in contact with the cam or rolling track. The position of the hole in question in the cam followers with stud that is not visible from the outside, is indicated by a reference on the head of the cam follower with stud.

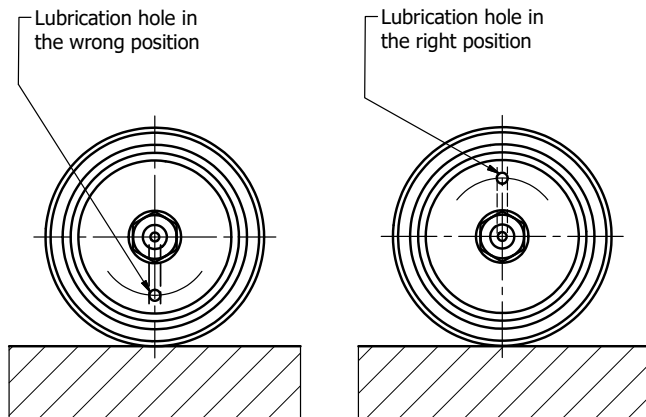

Side rest for the cam followers

In the event of relevant axial loads or functioning in the presence of vibrations, we recommend the outer diameter of the rest be at least equal to the d_A quota in the dimensions tablex.

Assembly hole diameter

The recommended tolerance for the slot hole in the cam follower with stud is d_1 H7.

Assembly pivot diameter

The recommended tolerance for the pivot to be inserted in the cam followers hole in the FG and FGU series is h5.

Nut clamping

The clamping torque given in the table allows the pivot to be clamped securely in the housing. An upper clamping torque can damage the product. The clamping torques are taken for non-greased threads; for greased threads, multiply the value of the torque in the table by 0.8. For products in the GC and GCU series supplied with two nuts, clamp the first nut with the recommended torque and then the second one.

Cam followers without stud with eccentric collar

The load applied to the cam follower without stud with eccentric collar generates a clamp that tends to rotate the stud in its housing. In order to avoid this effect generating a movement that could slacken the nut, adjust the eccentricity so that the cam follower is alongside the rolling track by rotating the stud in the same direction as the nut clamping.

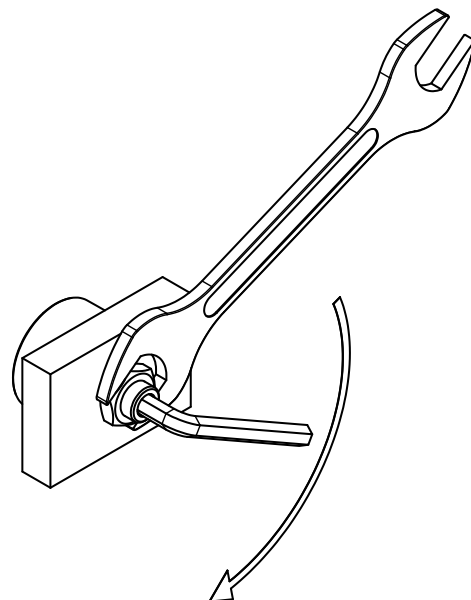
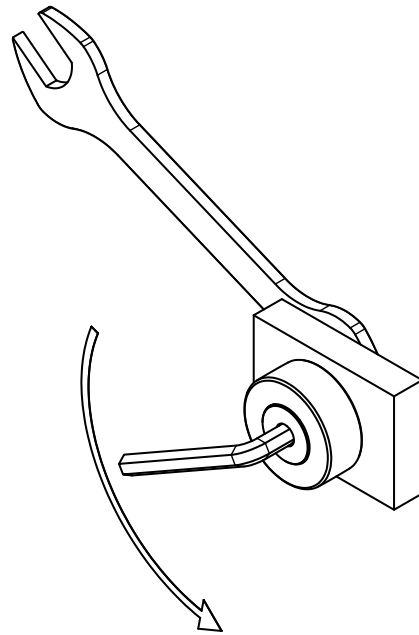

NOTES

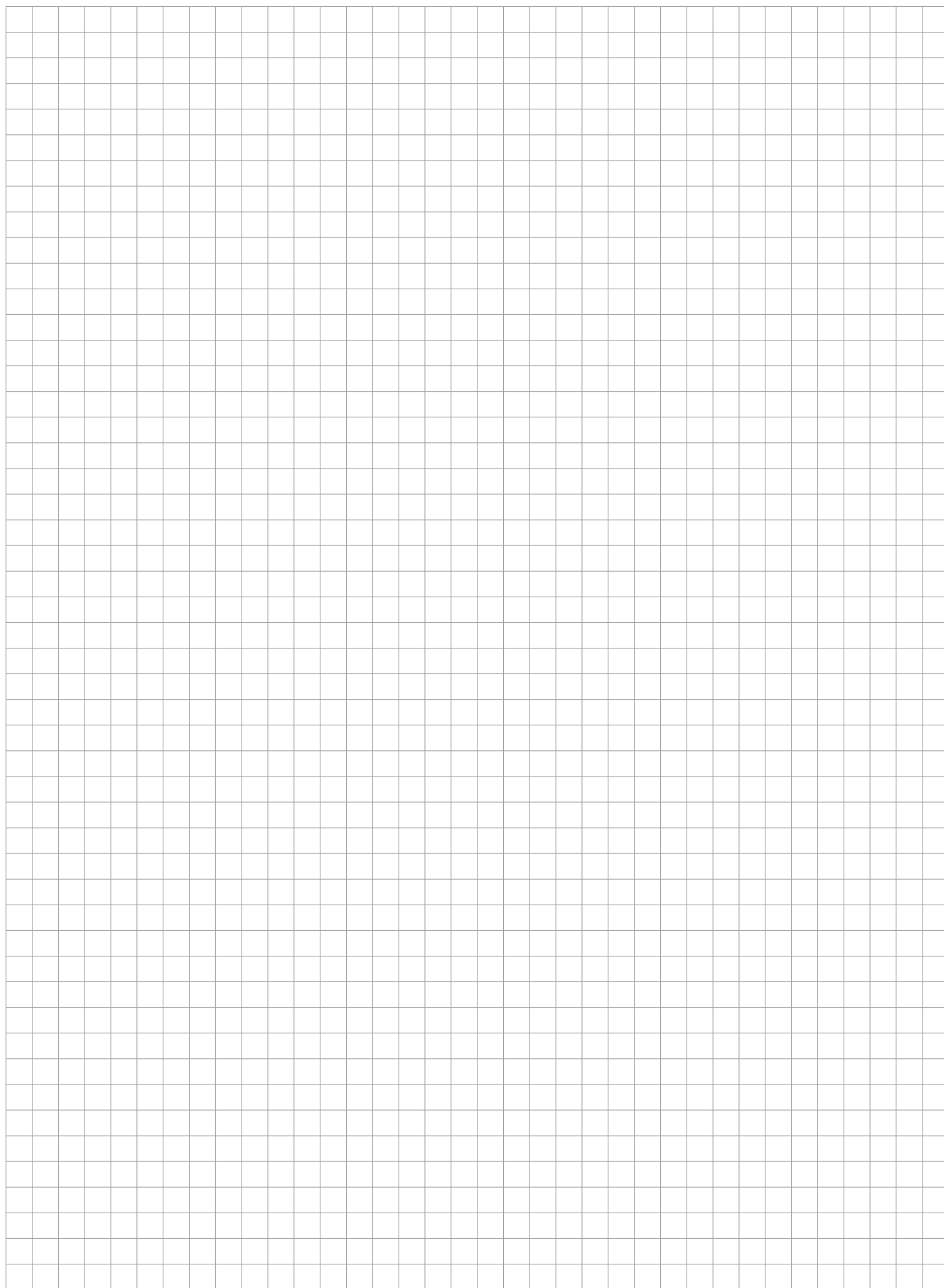



NADELLA / nadella.com

DURBAL / durbal.com

CHIAVETTE UNIFICATE / chiavette.com

IPIRANGA / ipirangahusillos.com

SHUTON / shuton.com

THE SPECIALIST FOR MOTION TECHNOLOGY

PF211EN

Version 02/2021 · Nadella Group | nadella.com | Errors and omissions excepted.